

3-3L SERIES

CENTRIFUGAL PUMPS according EN 733 (ex DIN 24255) STANDARD

End suction centrifugal pumps in accordance with EN 733 (ex DIN 24255) made of stainless steel **AISI 304** (3 series) and **AISI 316L** (3L series), applications include water boosting, heating systems, air-conditioning, washing systems and many other industrial applications. WRAS approved pumps are available upon request.

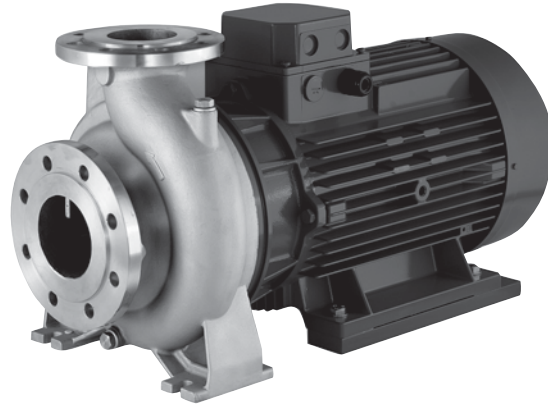

SPECIFICATIONS

- Maximum working pressure: 10 bar
- Liquid temperature: from -10°C to +110°C
- 110° C for H version

MATERIALS

- Pump body, impeller, casing cover and shaft in AISI 304 (3 series), in AISI 316L (3L series)
- Mechanical seal in carbon/ceramic/NBR for standard version
- Mechanical seal (3 series),
- Mechanical seal in SiC/SiC/FPM (3L series - 3L80 series HS version)
- Mechanical seal in carbon/ceramic/Viton for H version and 3L80 H version
- Mechanical seal in SiC/Carbon/FPM for 3L80 E version

TECHNICAL DATA

- Asynchronous 2 and 4 poles motor
- Insulation class F
- Protection degree IP55
- 1~230±10%
- 3~230/400V ± 10% 50Hz up to 4kW included, 400/690V ±10% above
- Thermal protection to be provided by the user

Available in 4 different versions, 2 and 4 poles

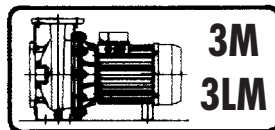

monobloc with extended motor shaft

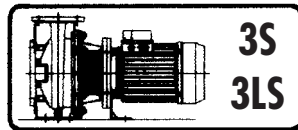

monobloc with standard motor and flexible coupling

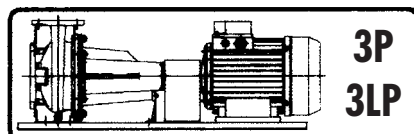

on basement with standard motor and flexible coupling

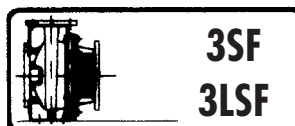
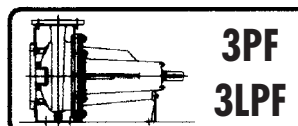

bare shaft pump



3-3L SERIES

CENTRIFUGAL PUMPS according EN 733 (ex DIN 24255) STANDARD

PERFORMANCE CHART at 2900 min⁻¹ (according to ISO 9906 Annex A)

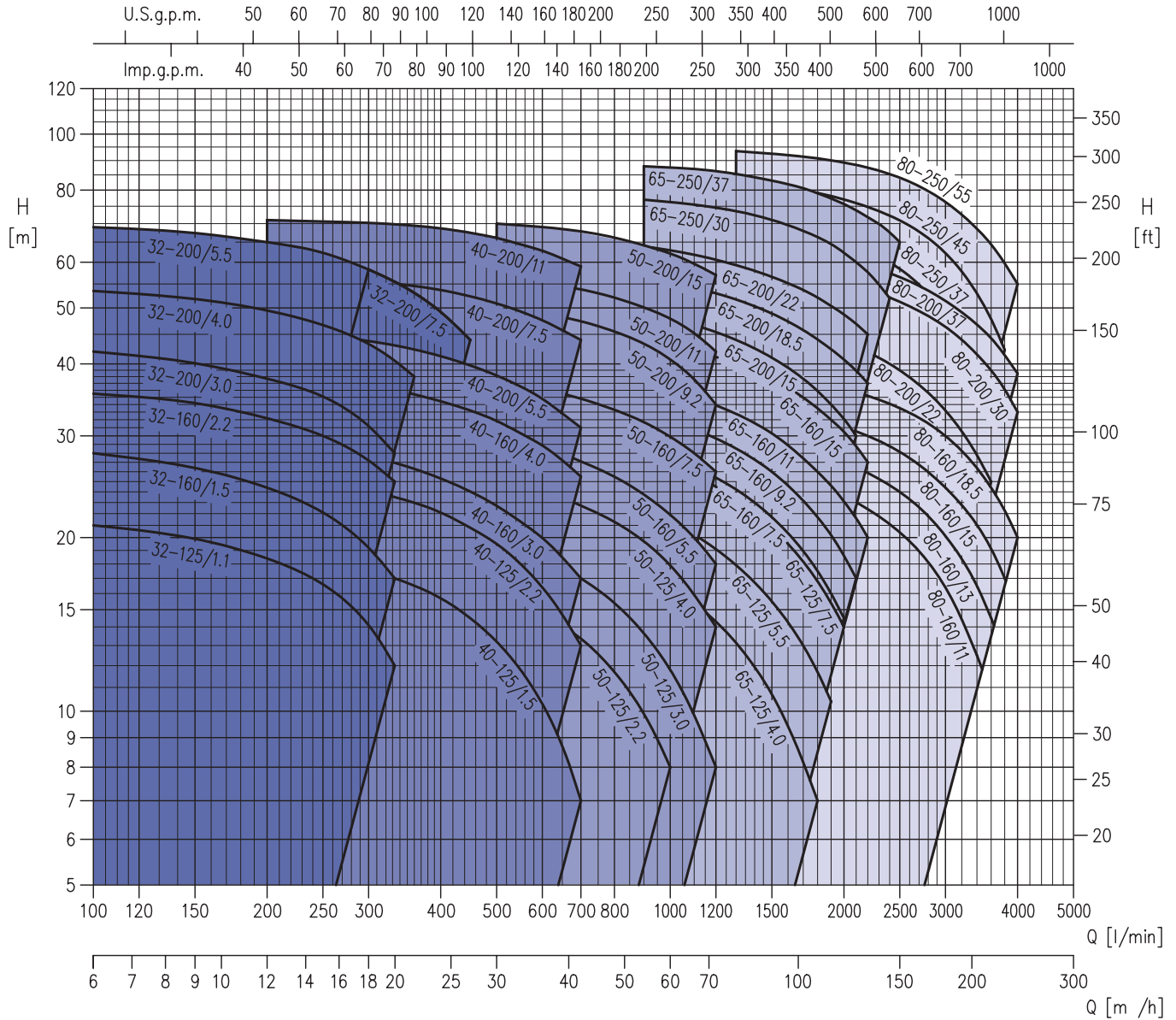

3-3L SERIES

CENTRIFUGAL PUMPS according EN 733 (ex DIN 24255) STANDARD

PERFORMANCE CHART at 1450 min⁻¹ (according to ISO 9906 Annex A)

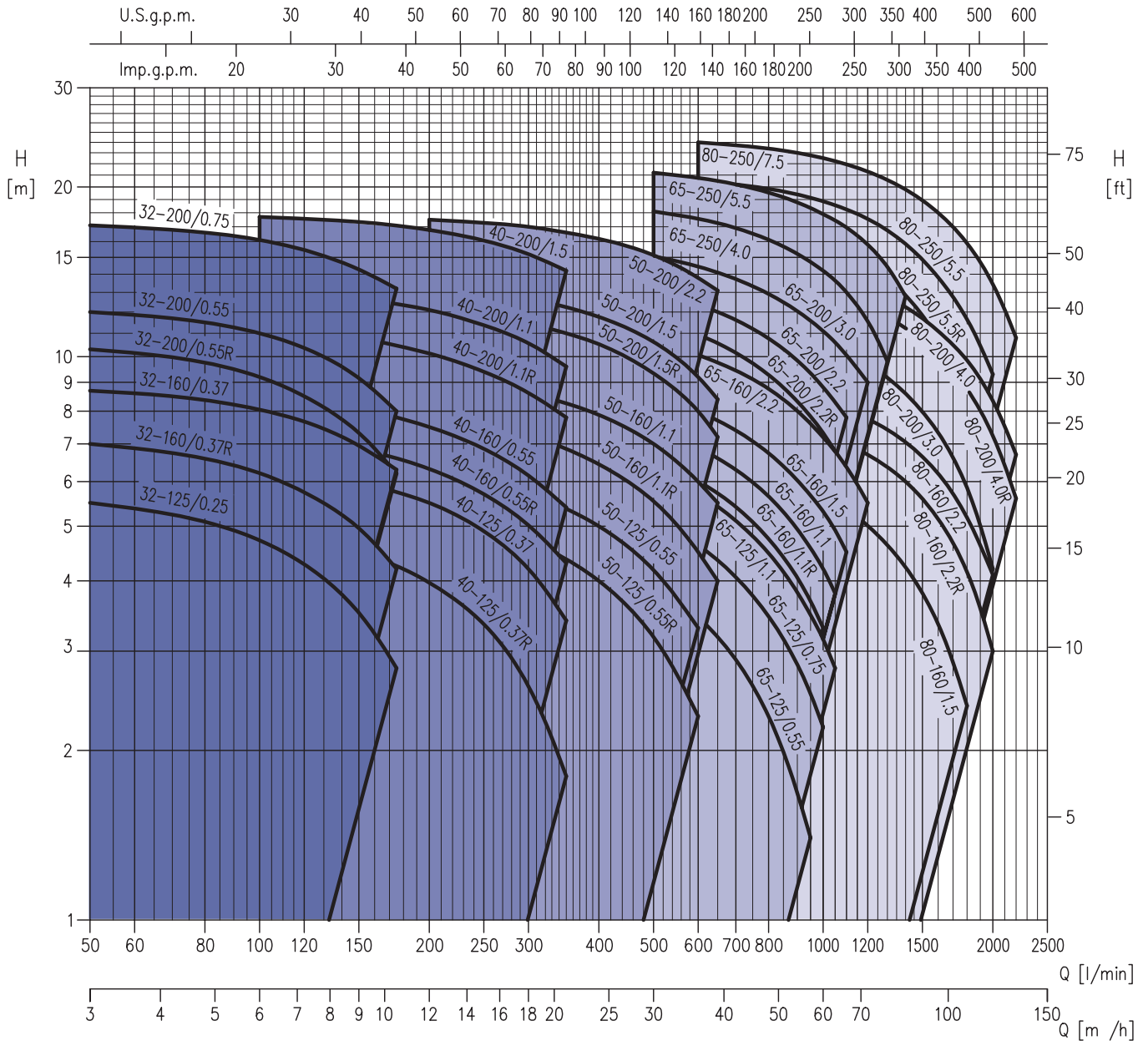

3-3L SERIES

CENTRIFUGAL PUMPS according EN 733 (ex DIN 24255) STANDARD

PERFORMANCE TABLE 32-40-50-65

4 Poles

Pump Type	kW	HP	Q= Capacity																
			H= Total head																
			l/min m ³ /h	50 3	100 6	160 9,6	200 12	250 15	300 18	350 21	400 24	500 30	600 36	650 39	800 48	950 57	1000 60	1050 63	1100 66
32-125/0.25	0.25	0.33	5,6	4,9	3,3	-	-	-	-	-	-	-	-	-	-	-	-	-	-
32-160/0.37R	0.37	0.5	7,2	6,3	4,5	-	-	-	-	-	-	-	-	-	-	-	-	-	-
32-160/0.37	0.37	0.5	8,7	8	6,7	-	-	-	-	-	-	-	-	-	-	-	-	-	-
32-200/0.55R	0.55	0.75	10,5	9,3	7	-	-	-	-	-	-	-	-	-	-	-	-	-	-
32-200/0.55	0.55	0.75	12	11	9,2	-	-	-	-	-	-	-	-	-	-	-	-	-	-
32-200/0.75	0.75	1	17,3	16,5	14,6	-	-	-	-	-	-	-	-	-	-	-	-	-	-
40-125/0.37R	0.37	0.5	-	4,5	4	3,6	3	2,3	1,5	-	-	-	-	-	-	-	-	-	-
40-125/0.37	0.37	0.5	-	6,2	5,7	5,2	4,6	3,8	3	-	-	-	-	-	-	-	-	-	-
40-160/0.55R	0.55	0.75	-	7,2	6,7	6,3	5,7	5	4,3	-	-	-	-	-	-	-	-	-	-
40-160/0.55	0.55	0.75	-	8,5	7,9	7,5	6,9	6,2	5,4	-	-	-	-	-	-	-	-	-	-
40-200/1.1R	1.1	1.5	-	11	10,5	10,1	9,6	9	8,3	-	-	-	-	-	-	-	-	-	-
40-200/1.1	1.1	1.5	-	12,7	12,3	11,9	11,2	10,4	9,4	-	-	-	-	-	-	-	-	-	-
40-200/1.5	1.5	2	-	17,8	17,4	16,9	16,2	15,3	14,2	-	-	-	-	-	-	-	-	-	-
50-125/0.55R	0.55	0.75	-	-	-	4,9	4,7	4,4	4,2	3,8	3	2	-	-	-	-	-	-	-
50-125/0.55	0.55	0.75	-	-	-	5,8	5,6	5,4	5,2	4,9	4,1	3,2	-	-	-	-	-	-	-
50-160/1.1R	1.1	1.5	-	-	-	7,7	7,5	7,2	6,9	6,5	5,6	4,5	-	-	-	-	-	-	-
50-160/1.1	1.1	1.5	-	-	-	9	8,8	8,5	8,2	7,8	6,9	5,8	-	-	-	-	-	-	-
50-200/1.5R	1.5	2	-	-	-	12,1	11,8	11,5	11,1	10,6	9,5	8	-	-	-	-	-	-	-
50-200/1.5	1.5	2	-	-	-	13	12,7	12,3	11,9	11,5	10,5	9,1	-	-	-	-	-	-	-
50-200/2.2	2.2	3	-	-	-	17,7	17,5	17,2	16,8	16,4	15,4	14	-	-	-	-	-	-	-
65-125/0.55	0.55	0.75	-	-	-	-	-	4,8	4,6	4,4	4,0	3,5	3,2	2,3	1,4	-	-	-	-
65-125/0.75	0.75	1	-	-	-	-	-	6	5,8	5,7	5,2	4,6	4,4	3,5	2,5	2,2	-	-	-
65-125/1.1	1.1	1.5	-	-	-	-	-	7,2	7	5,8	6,3	5,8	5,4	4,5	3,5	3,2	2,8	-	-
65-160/1.1	1.1	1.5	-	-	-	-	-	-	8,1	8,0	7,4	7,0	6,6	5,7	4,6	4,2	3,8	-	-
65-160/1.5	1.5	2	-	-	-	-	-	-	9,2	9	8,5	8	7,7	6,7	5,7	5,3	4,9	4,5	-
65-160/2.2	2.2	3	-	-	-	-	-	-	11,3	11,1	10,6	10	9,8	8,8	7,6	7,2	6,8	6,4	5,5
65-200/2.2R	2.2	3	-	-	-	-	-	-	12,4	12,2	11,6	11	10,6	9,3	7,8	7,3	6,8	-	-
65-200/2.2	2.2	3	-	-	-	-	-	-	13,9	13,7	13,0	12,4	12	10,8	9,3	8,8	8,3	7,8	-
65-200/3.0	3	4	-	-	-	-	-	-	15,8	15,6	15,06	14,5	14,1	12,9	11,6	11,1	10,6	10,1	9

PERFORMANCE TABLE 80

4 Poles

Pump type	kW	HP	Absorbed Current (A)			Q=Capacity									
			Three-phase			H=Total head									
			230V	400V	690V	l/min m ³ /h	0	600	800	1000	1200	1400	1600	1800	2000
3LM4 80-160/1.5	1.5	2	5,4	3,13	-	7,3	6,8	6,3	5,7	5	4,2	3,4	2,4	-	-
3LS4 80-160/1.5	1.5	2	5	2,88	-	7,3	6,8	6,3	5,7	5	4,2	3,4	2,4	-	-
3LP4 80-160/1.5	1.5	2	5	2,88	-	7,3	6,8	6,3	5,7	5	4,2	3,4	2,4	-	-
3LM4 80-160/2.2R	2.2	3	7,3	4,25	-	8,6	8,1	7,8	7,3	6,7	6	5,2	4,2	3	-
3LS4 80-160/2.2R	2.2	3	7,6	4,48	-	8,6	8,1	7,8	7,3	6,7	6	5,2	4,2	3	-
3LP4 80-160/2.2R	2.2	3	7,6	4,48	-	8,6	8,1	7,8	7,3	6,7	6	5,2	4,2	3	-
3LM4 80-160/2.2	2.2	3	7,8	4,75	-	9,5	9,1	8,8	8,3	7,8	7,1	6,2	5,2	4,1	-
3LS4 80-160/2.2	2.2	3	8,8	5,13	-	9,5	9,1	8,8	8,3	7,8	7,1	6,2	5,2	4,1	-
3LP4 80-160/2.2	2.2	3	8,8	5,13	-	9,5	9,1	8,8	8,3	7,8	7,1	6,2	5,2	4,1	-
3LM4 80-200/3	3	4	10,2	5,9	-	12,4	12	11,5	10,7	9,7	8,6	7,3	5,9	4,2	-
3LS4 80-200/3	3	4	8,9	5,12	-	12,4	12	11,5	10,7	9,7	8,6	7,3	5,9	4,2	-
3LP4 80-200/3	3	4	8,9	5,12	-	12,4	12	11,5	10,7	9,7	8,6	7,3	5,9	4,2	-
3LM4 80-200/4R	4	5,5	13,7	7,9	-	14,8	14,4	13,9	13,2	12,2	11,2	10,1	8,8	7,2	5,6
3LS4 80-200/4R	4	5,5	12,1	6,99	-	14,8	14,4	13,9	13,2	12,2	11,2	10,1	8,8	7,2	5,6
3LP4 80-200/4R	4	5,5	12,1	6,99	-	14,8	14,4	13,9	13,2	12,2	11,2	10,1	8,8	7,2	5,6
3LM4 80-200/4	4	5,5	14,7	8,5	-	16	15,4	14,9	14,1	13,2	12,3	11,1	9,9	8,4	6,7
3LS4 80-200/4	4	5,5	13,4	7,75	-	16	15,4	14,9	14,1	13,2	12,3	11,1	9,9	8,4	6,7
3LP4 80-200/4	4	5,5	13,4	7,75	-	16	15,4	14,9	14,1	13,2	12,3	11,1	9,9	8,4	6,7
3LM4 80-250/5.5R	5.5	7,5	-	9,4	5,42	18,5	17,7	17	16	14,6	12,9	10,7	8,4	-	-
3LS4 80-250/5.5R	5.5	7,5	-	8,79	5,07	18,5	17,7	17	16	14,6	12,9	10,7	8,4	-	-
3LP4 80-250/5.5R	5.5	7,5	-	8,79	5,07	18,5	17,7	17	16	14,6	12,9	10,7	8,4	-	-
3LM4 80-250/5.5	5.5	7,5	-	11,3	6,52	21,2	20,5	19,9	18,9	17,6	15,9	13,8	11,7	9,3	-
3LS4 80-250/5.5	5.5	7,5	-	10,88	6,28	21,2	20,5	19,9	18,9	17,6	15,9	13,8	11,7	9,3	-
3LP4 80-250/5.5	5.5	7,5	-	10,88	6,28	21,2	20,5	19,9	18,9	17,6	15,9	13,8	11,7	9,3	-
3LM4 80-250/7.5	7.5	10	-	14,7	8,49	24,5	24	23,4	22,5	21,3	19,8	18	15,9	13,5	10,8
3LS4 80-250/7.5	7.5	10	-	13,6	7,85	24,5	24	23,4	22,5	21,3	19,8	18	15,9	13,5	10,8
3LP4 80-250/7.5	7.5	10	-	13,6	7,85	24,5	24	23,4	22,5	21,3	19,8	18	15,9	13,5	10,8



3-3L SERIES

CENTRIFUGAL PUMPS according EN 733 (ex DIN 24255) STANDARD

PERFORMANCE CURVES 3(L)M-3(L)S-3(L)P 32 at 2900 min⁻¹ (according to ISO 9906 Annex A)

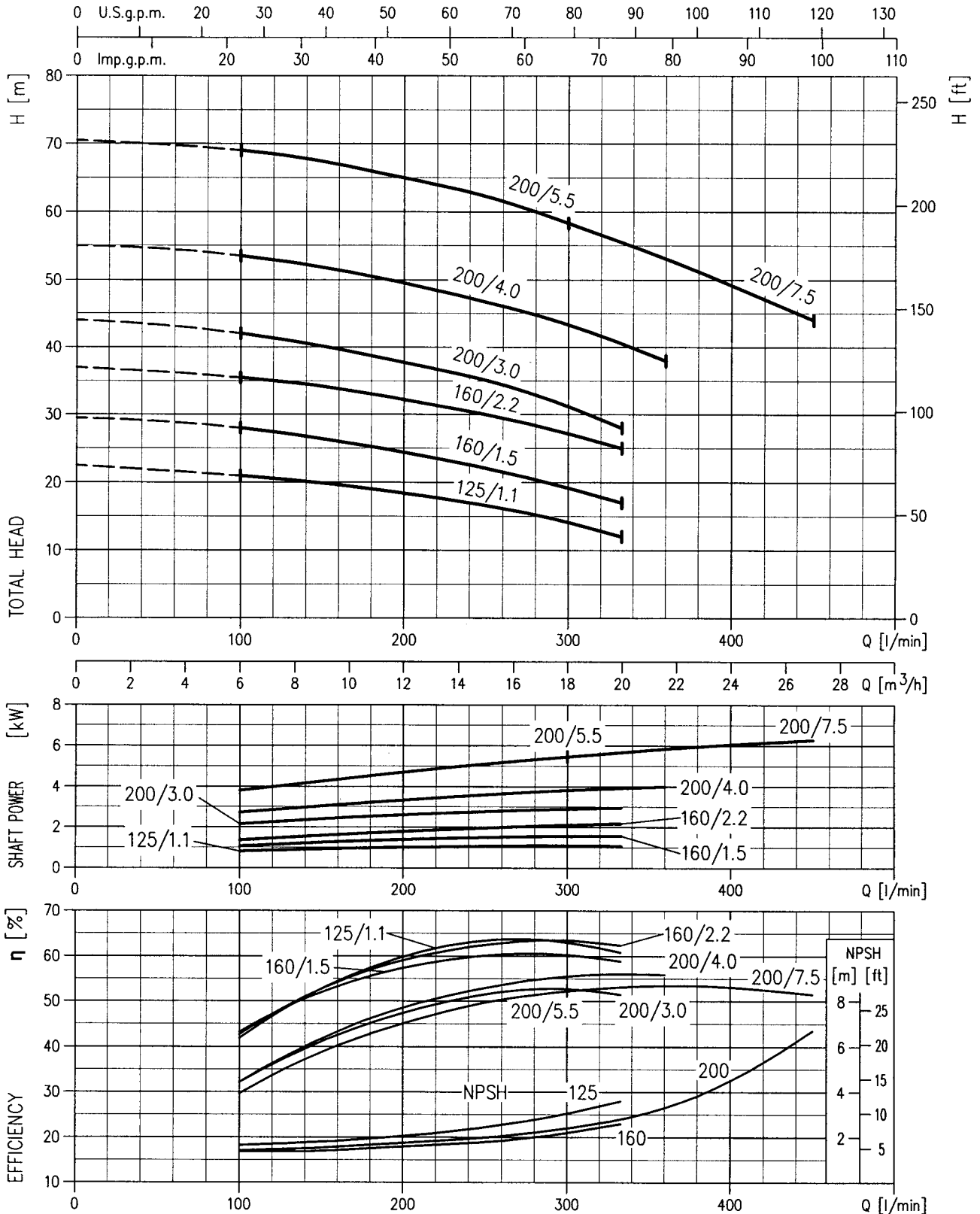



3-3L SERIES

CENTRIFUGAL PUMPS according EN 733 (ex DIN 24255) STANDARD

PERFORMANCE CURVES 3(L)M-3(L)S-3(L)P 40 at 2900 min⁻¹ (according to ISO 9906 Annex A)

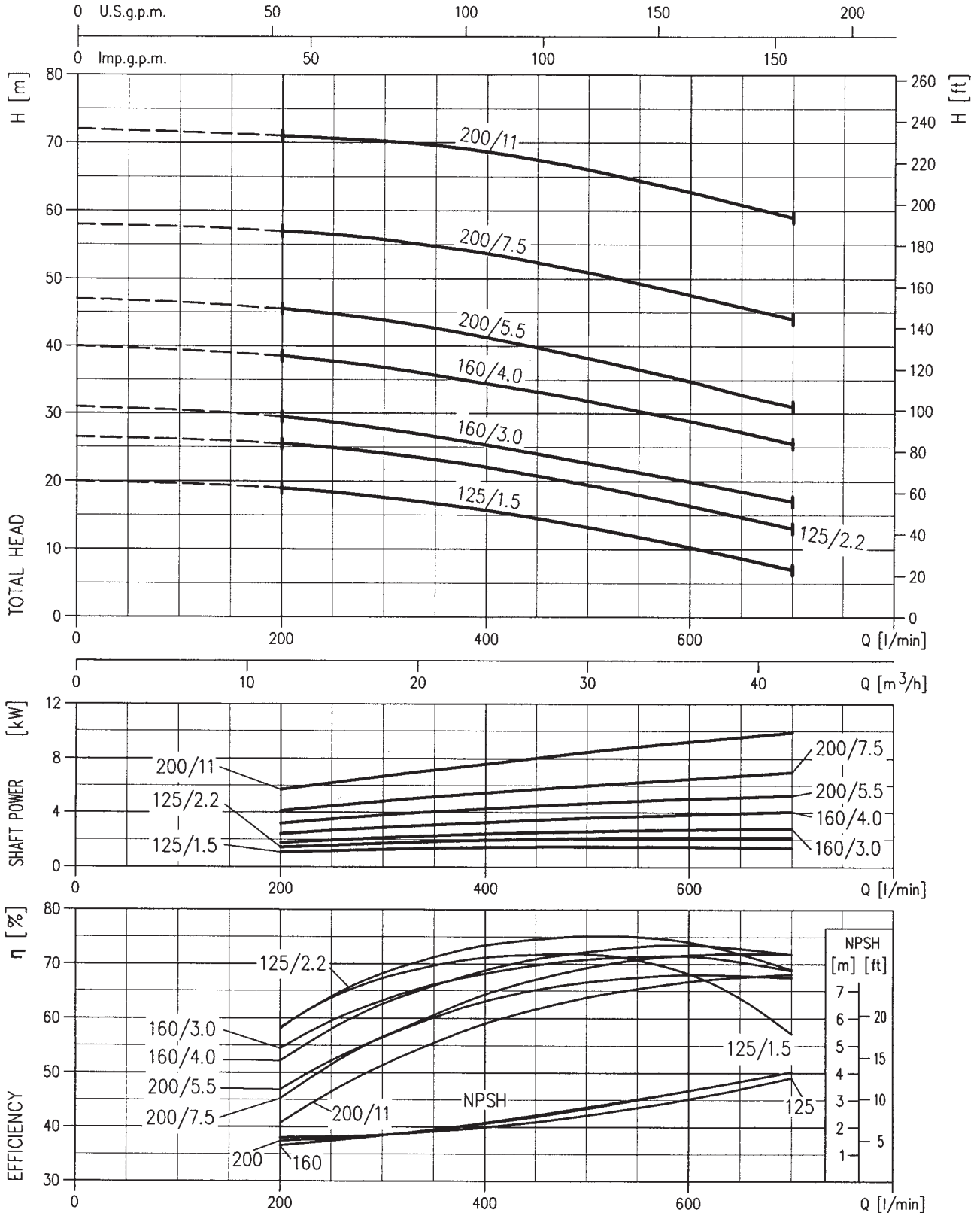



3-3L SERIES

CENTRIFUGAL PUMPS according EN 733 (ex DIN 24255) STANDARD

PERFORMANCE CURVES 3(L)M-3(L)S-3(L)P 50 at 2900 min⁻¹ (according to ISO 9906 Annex A)

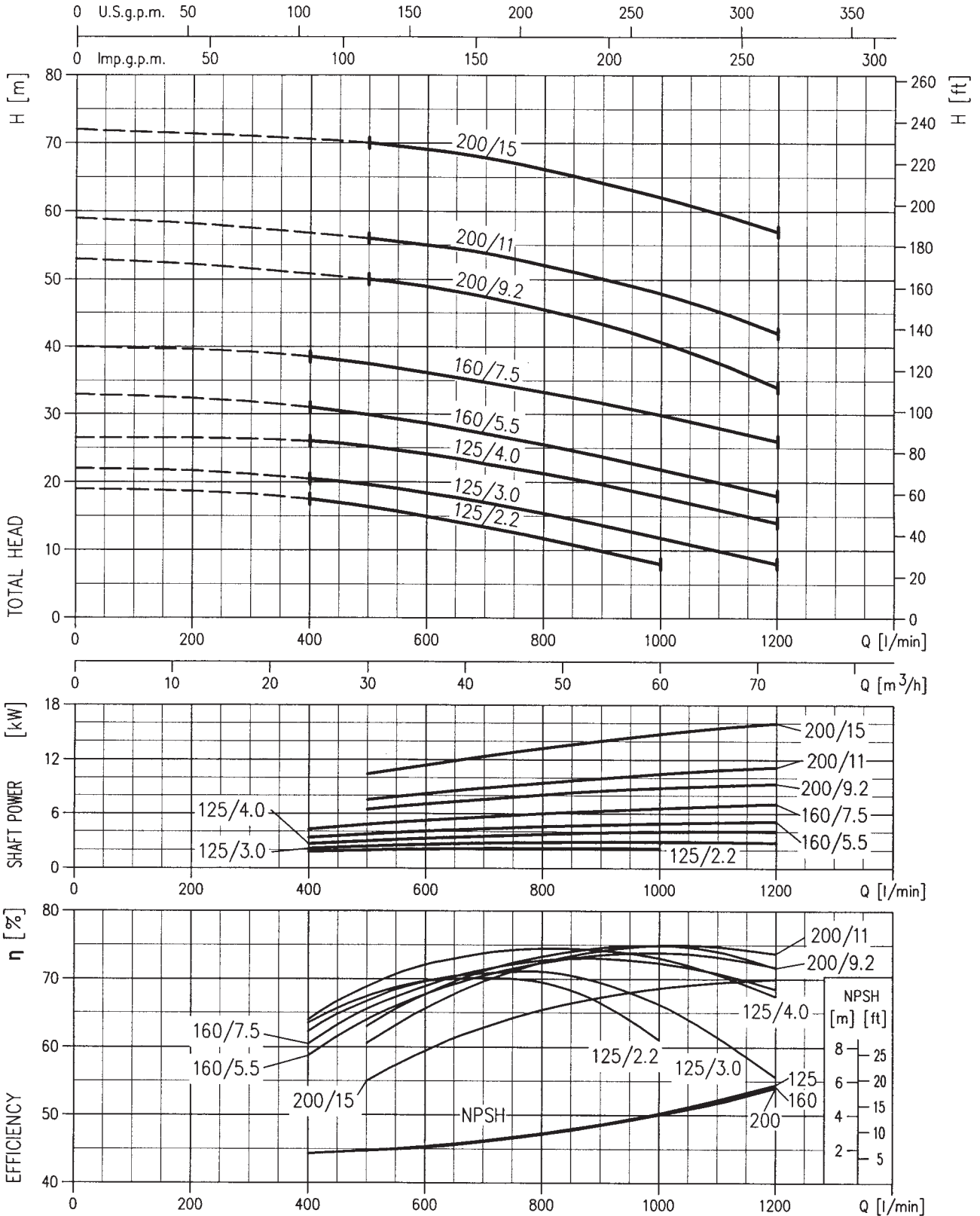



3-3L SERIES

CENTRIFUGAL PUMPS according EN 733 (ex DIN 24255) STANDARD

PERFORMANCE CURVES 3(L)M-3(L)S-3(L)P 65 at 2900 min⁻¹ (according to ISO 9906 Annex A)

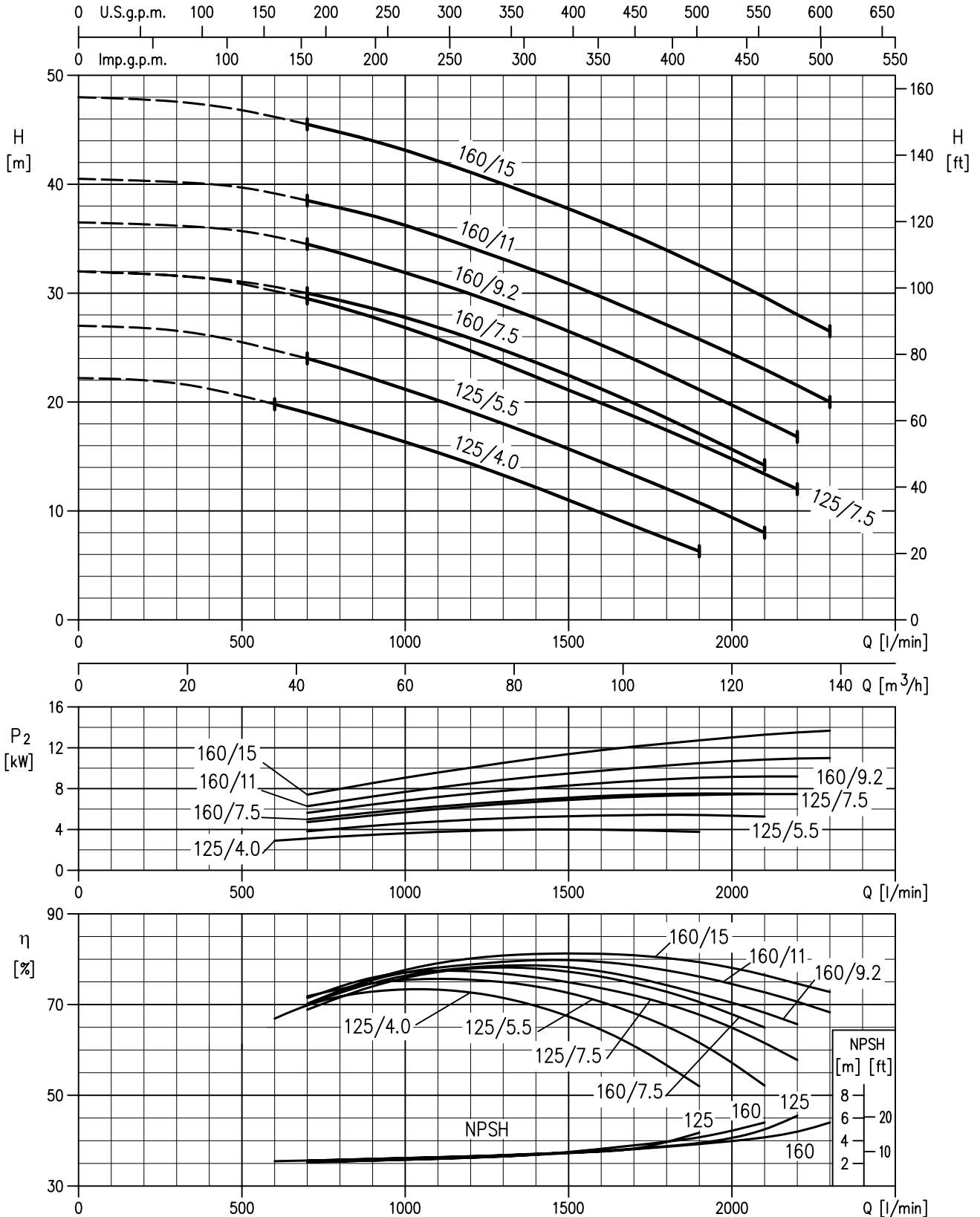

3-3L SERIES

CENTRIFUGAL PUMPS according EN 733 (ex DIN 24255) STANDARD

PERFORMANCE CURVES 3(L)M-3(L)S-3(L)P 65 at 2900 min⁻¹ (according to ISO 9906 Annex A)

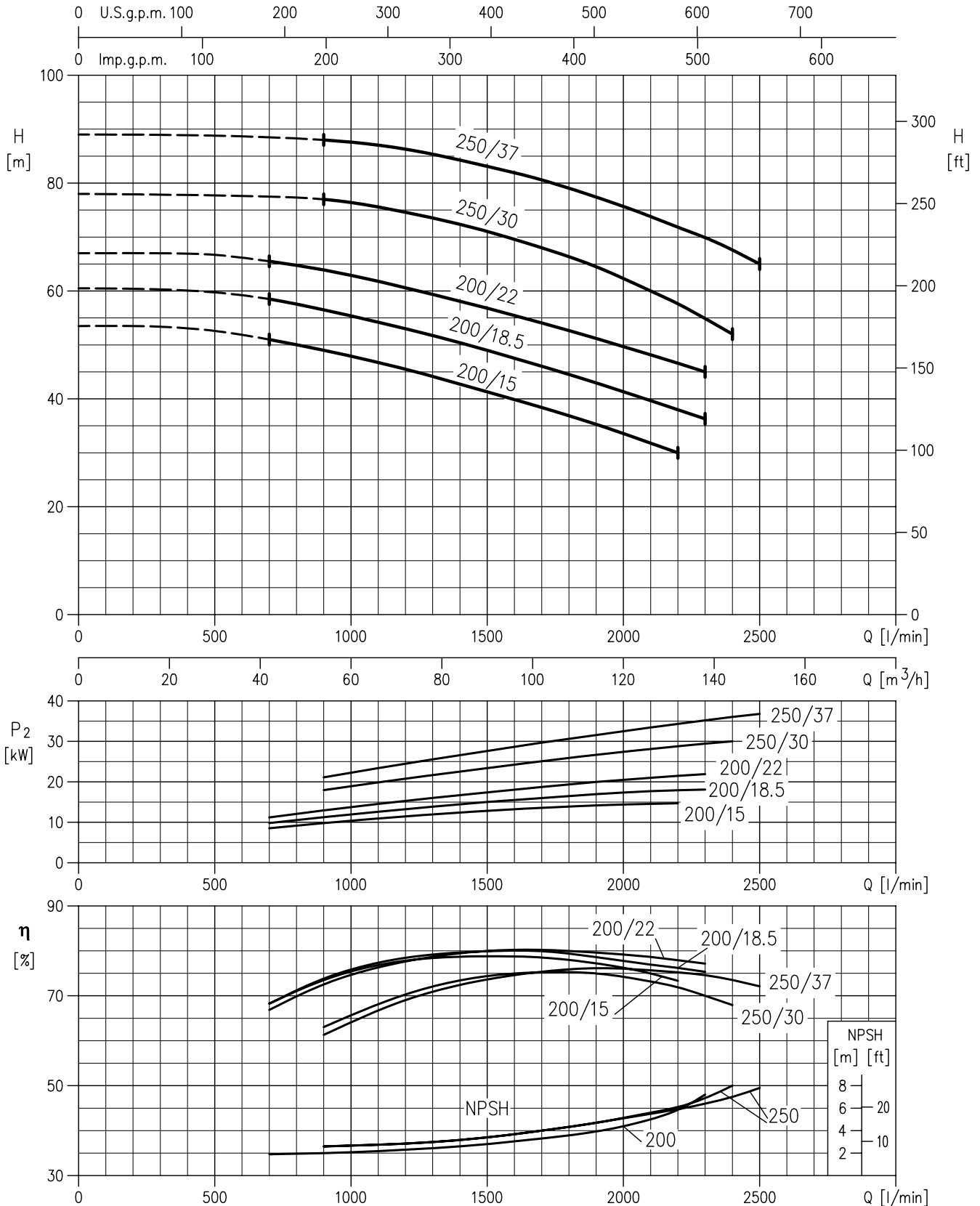

3-3L SERIES

CENTRIFUGAL PUMPS according EN 733 (ex DIN 24255) STANDARD

PERFORMANCE CURVES 3LM-3LS-3LP 80 at 2900 min⁻¹

(according to ISO 9906 Annex A)

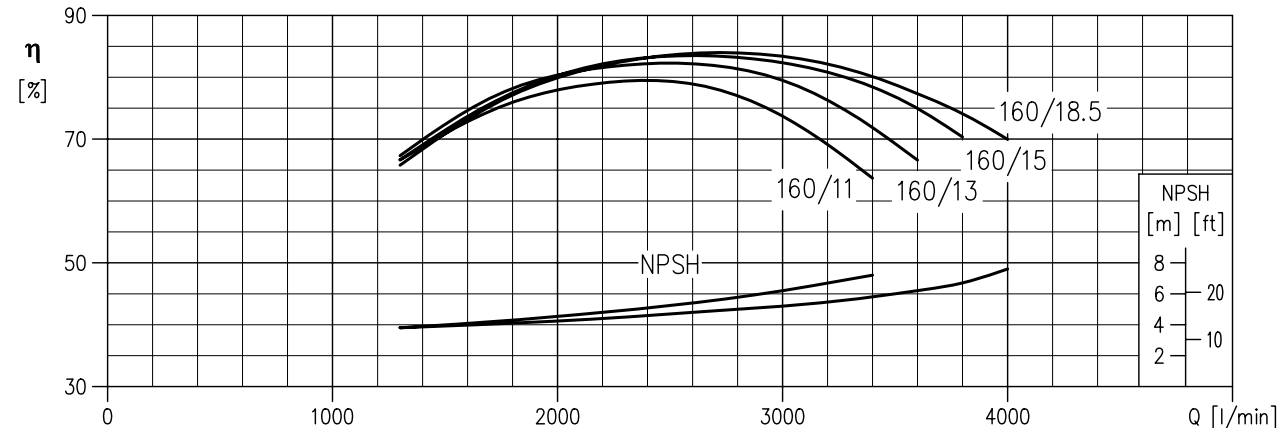
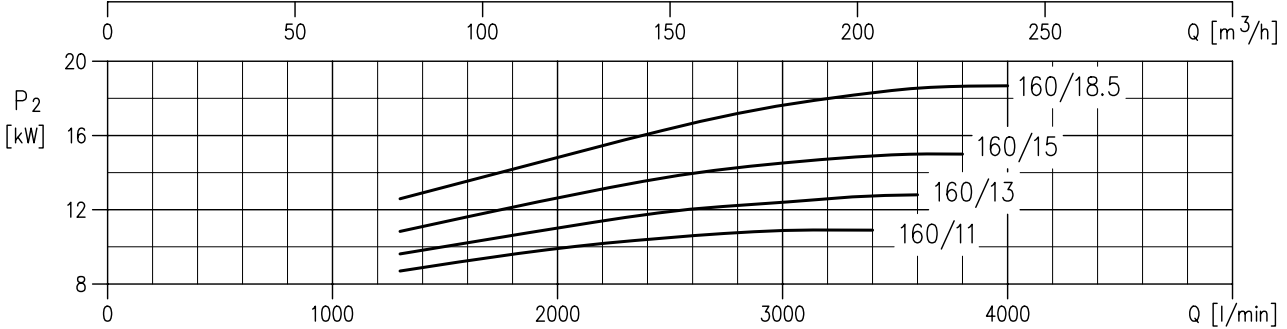
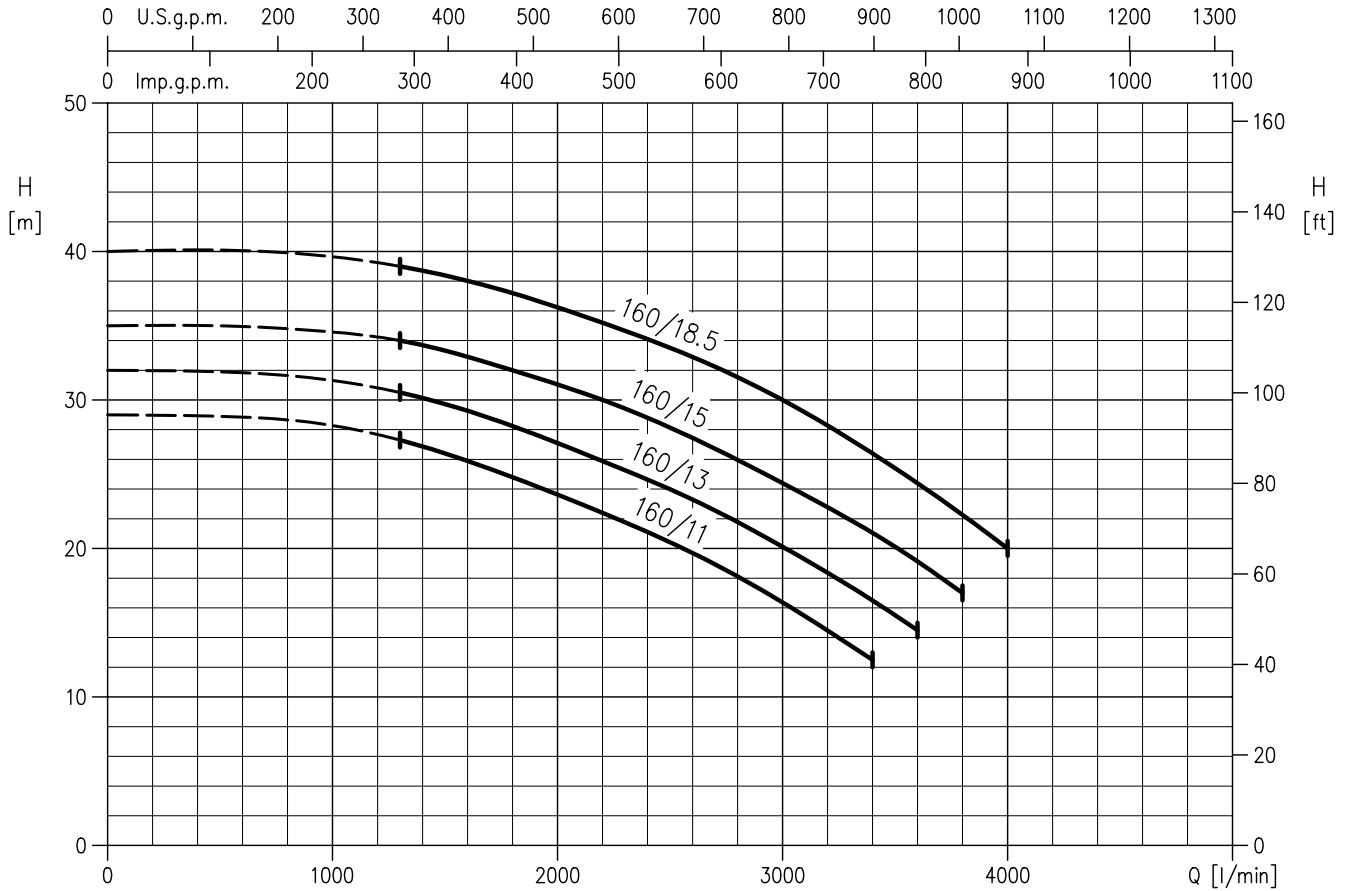

3-3L SERIES

CENTRIFUGAL PUMPS according EN 733 (ex DIN 24255) STANDARD

PERFORMANCE CURVES 3LM-3LS-3LP 80 at 2900 min⁻¹

(according to ISO 9906 Annex A)

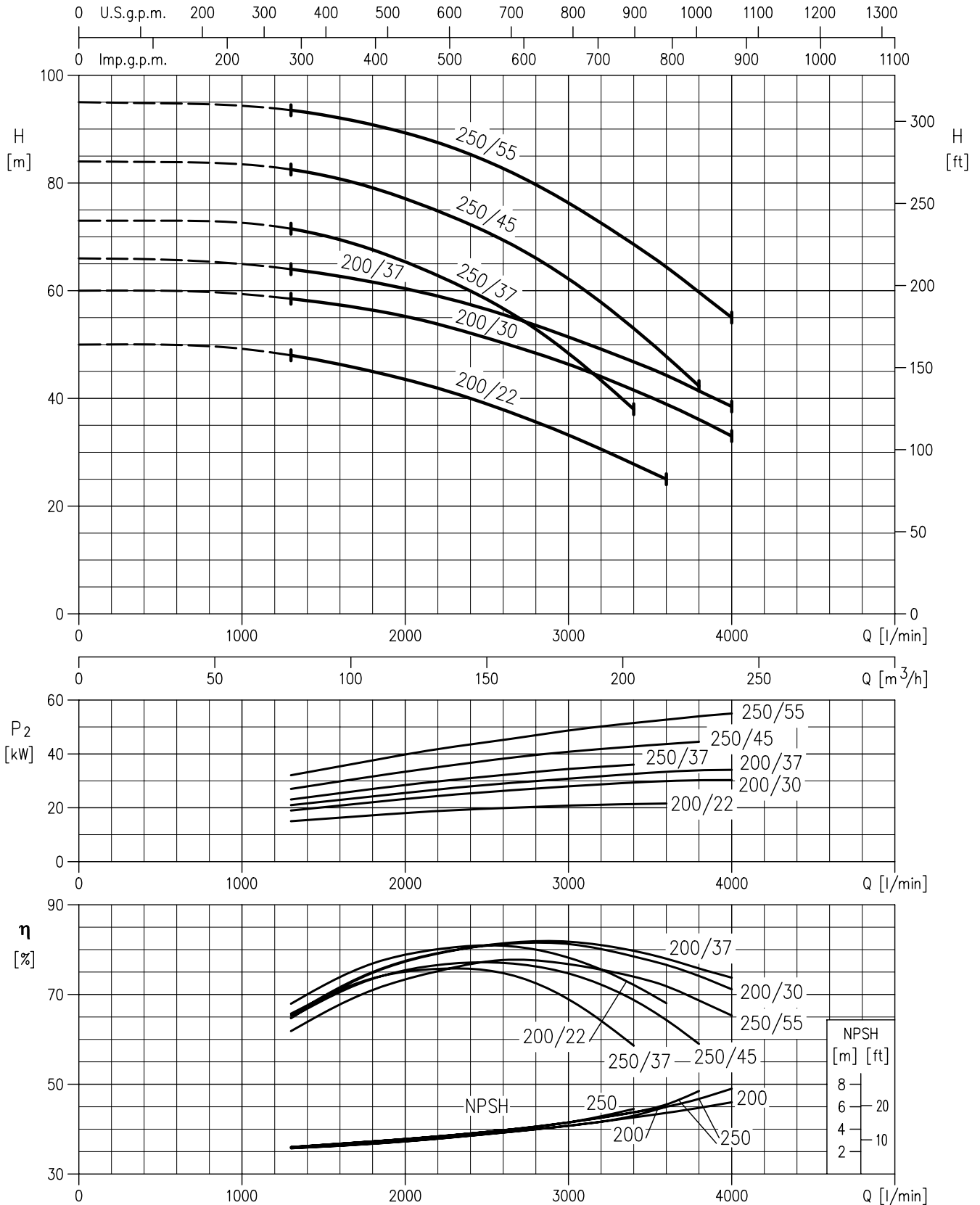



3-3L SERIES

CENTRIFUGAL PUMPS according EN 733 (ex DIN 24255) STANDARD

PERFORMANCE CURVES 3(L)M-3(L)S-3(L)P 32 at 1450 min⁻¹ (according to ISO 9906 Annex A)

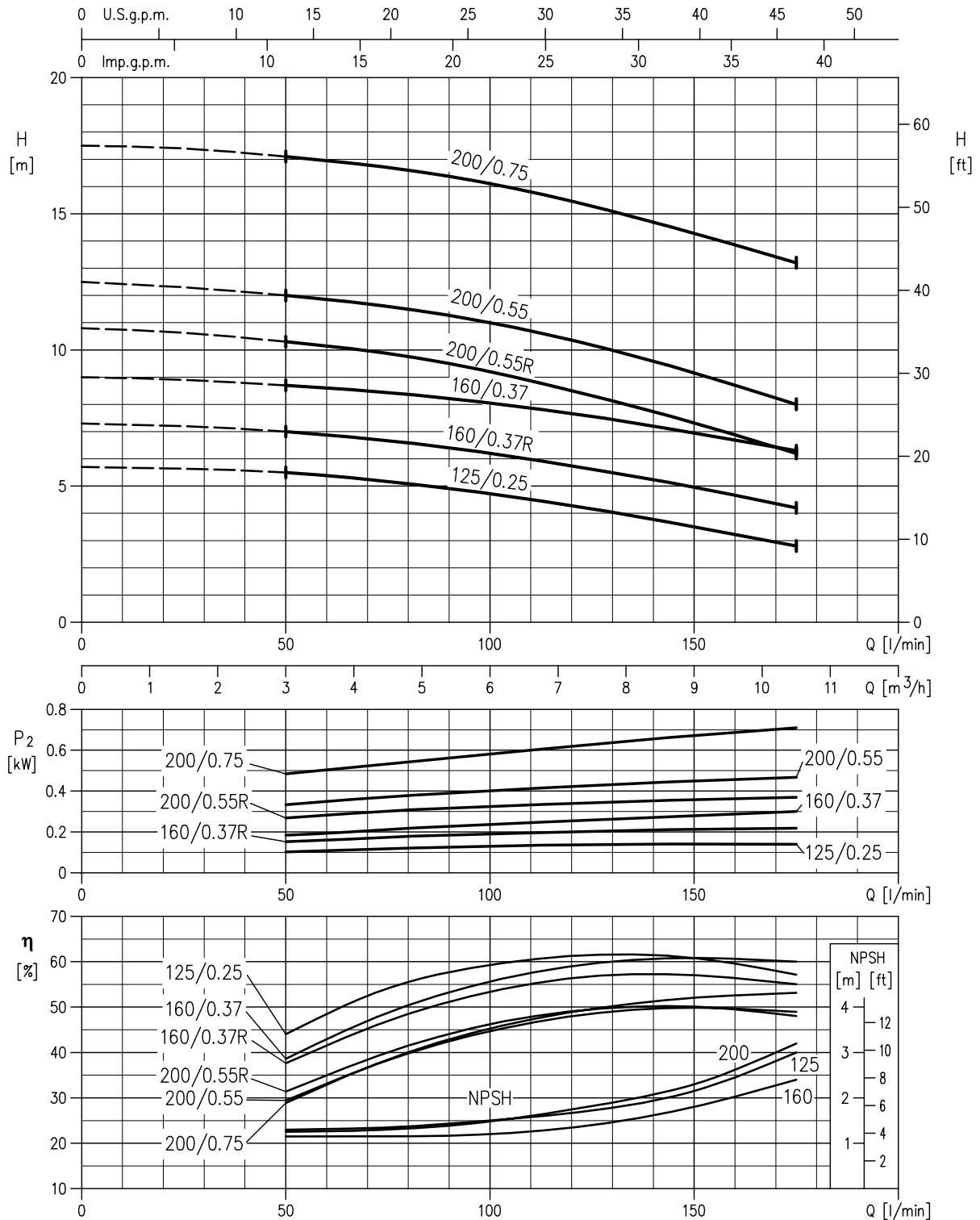



3-3L SERIES

CENTRIFUGAL PUMPS according EN 733 (ex DIN 24255) STANDARD

PERFORMANCE CURVES 3(L)M-3(L)S-3(L)P 40 at 1450 min⁻¹ (according to ISO 9906 Annex A)

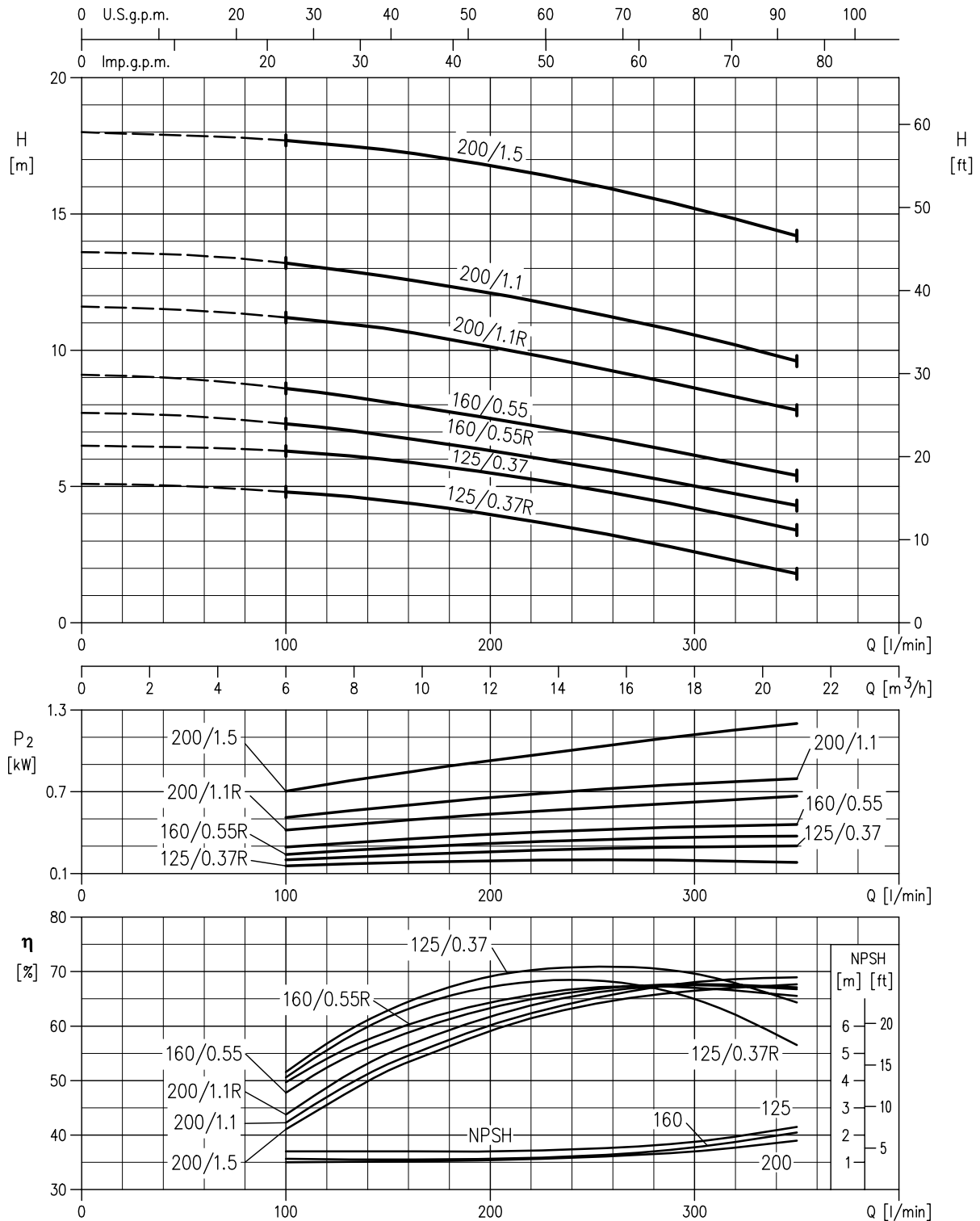



3-3L SERIES

CENTRIFUGAL PUMPS according EN 733 (ex DIN 24255) STANDARD

PERFORMANCE CURVES 3(L)M-3(L)S-3(L)P 50 at 1450 min⁻¹ (according to ISO 9906 Annex A)

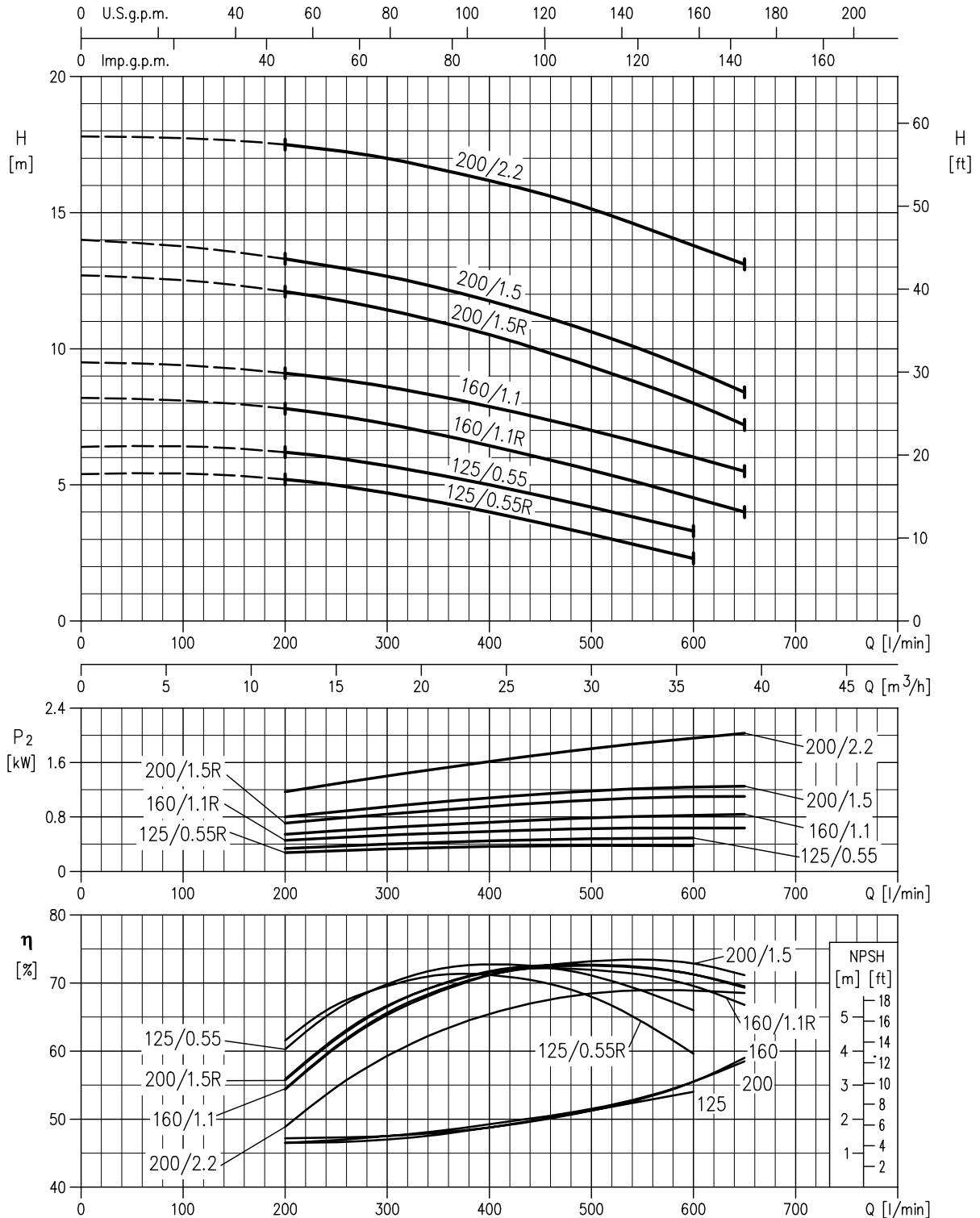

PERFORMANCE CURVES 3(L)M-3(L)S-3(L)P 65 at 1450 min⁻¹

(according to ISO 9906 Annex A)

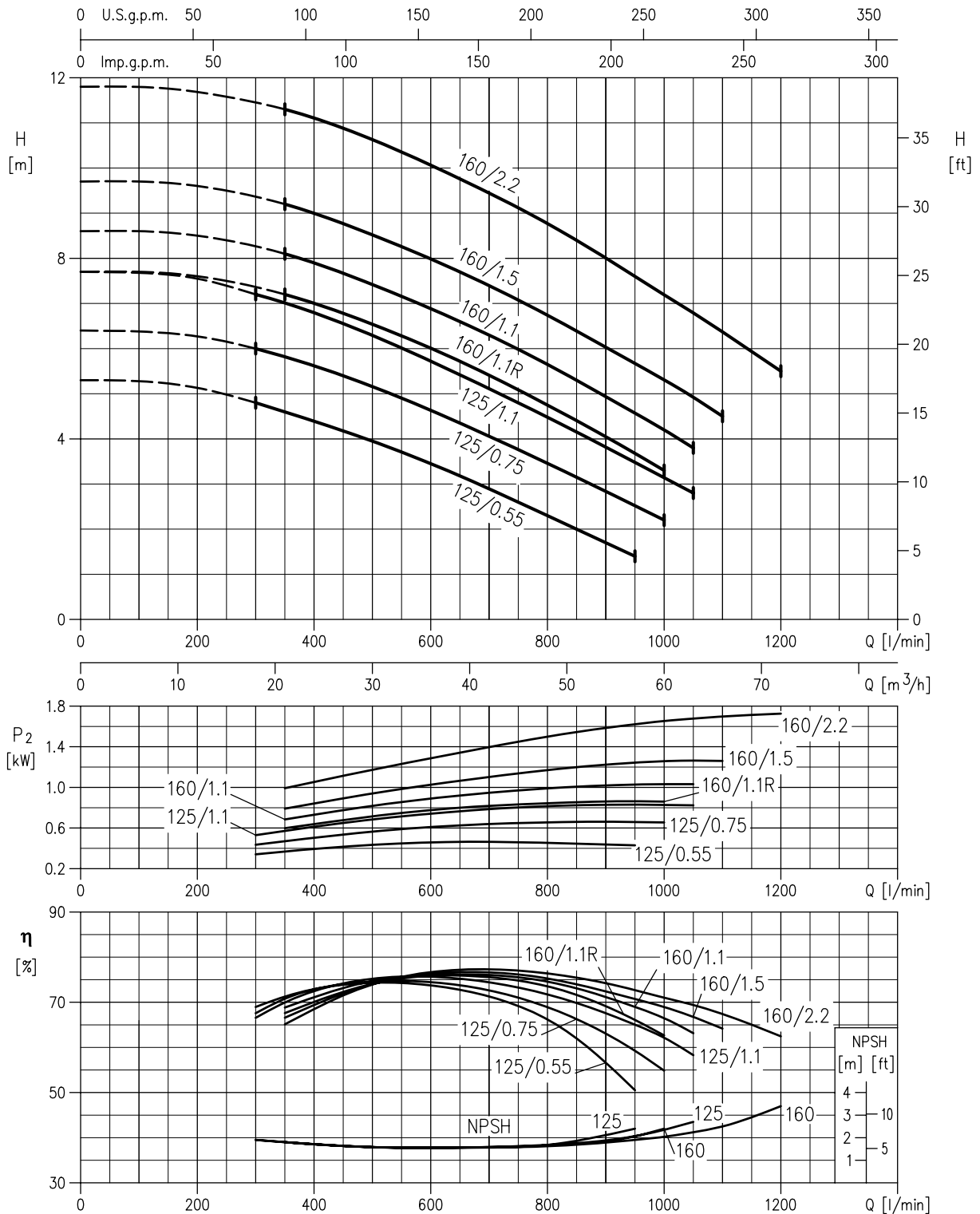

PERFORMANCE CURVES 3(L)M-3(L)S-3(L)P 65 at 1450 min⁻¹

(according to ISO 9906 Annex A)

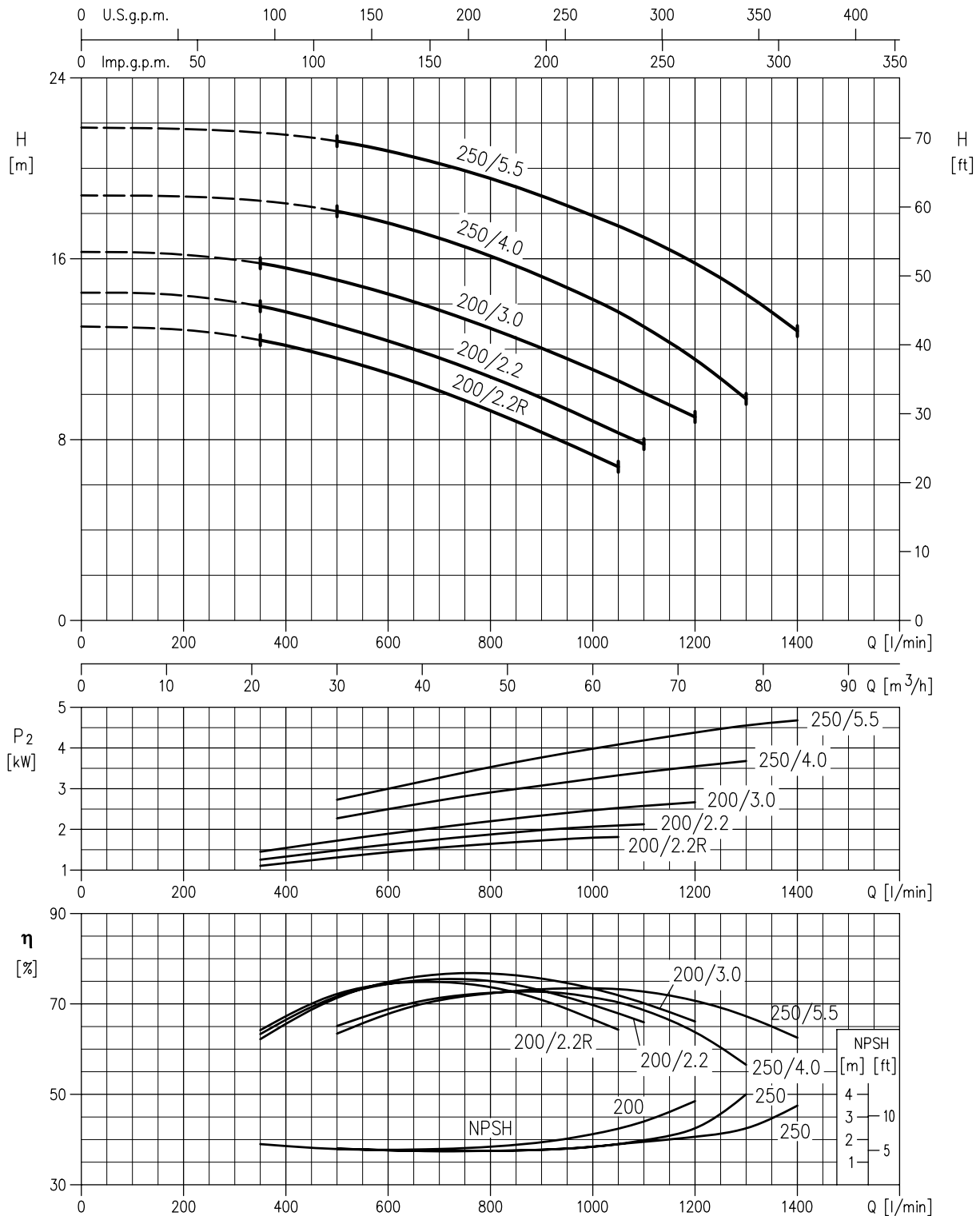

PERFORMANCE CURVES 3LM - 3LS - 3LP 80 at 1450 min⁻¹

(according to ISO 9906 Annex A)

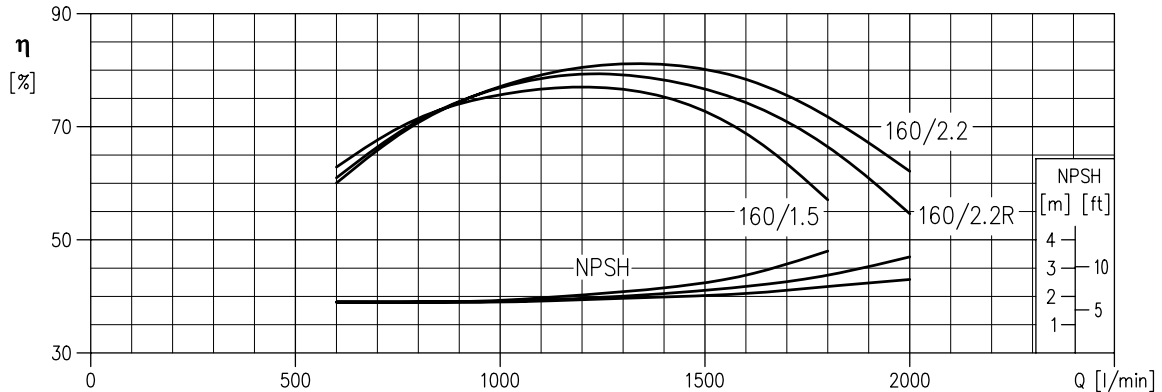
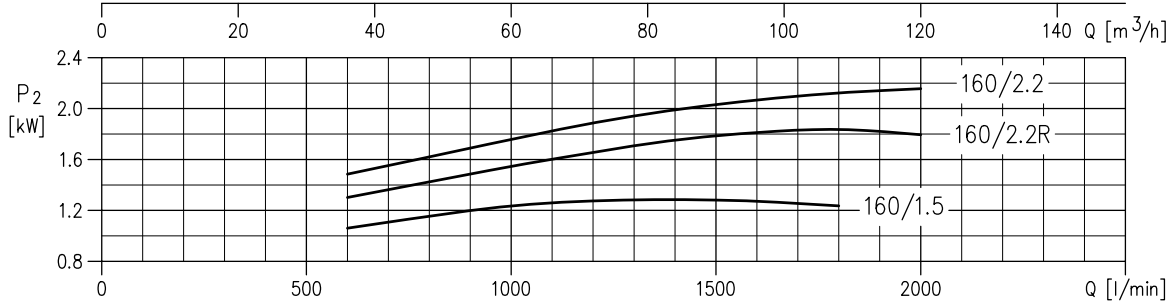
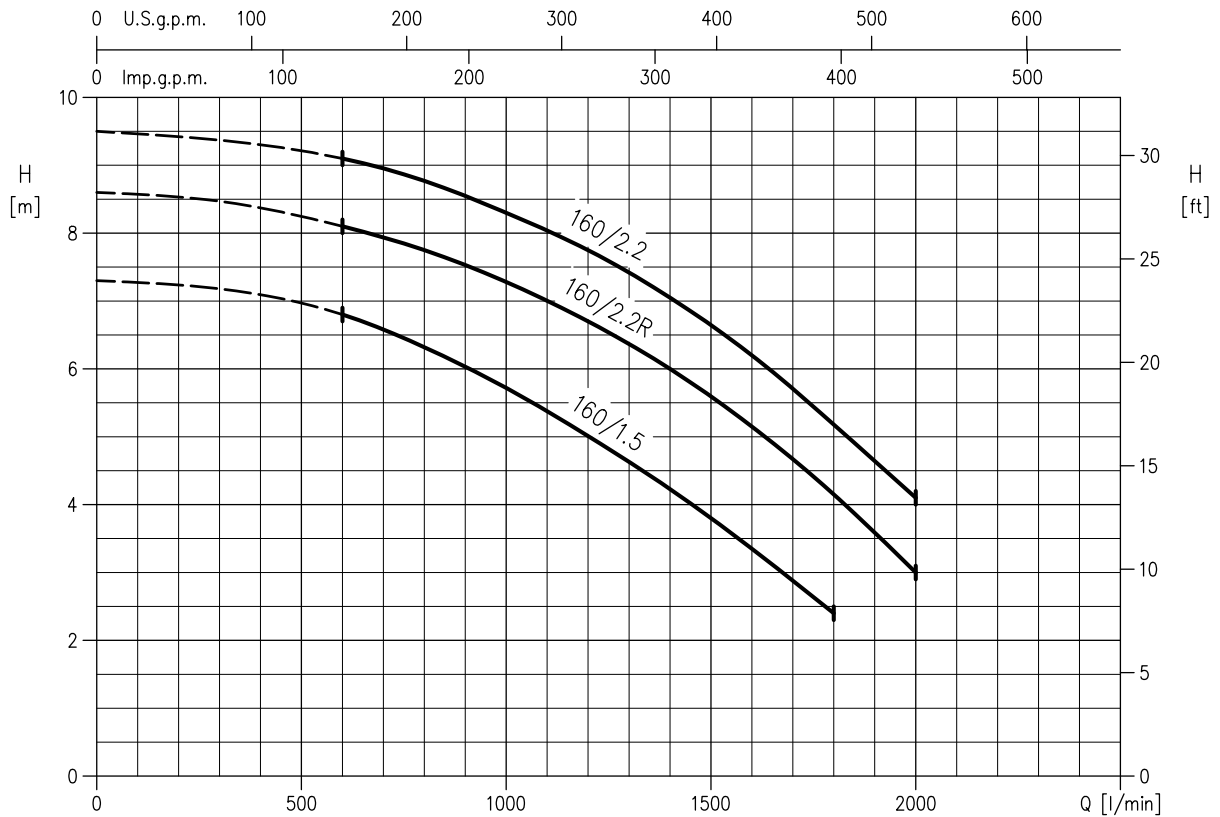

PERFORMANCE CURVES 3LM - 3LS - 3LP 80 at 1450 min⁻¹

(according to ISO 9906 Annex A)

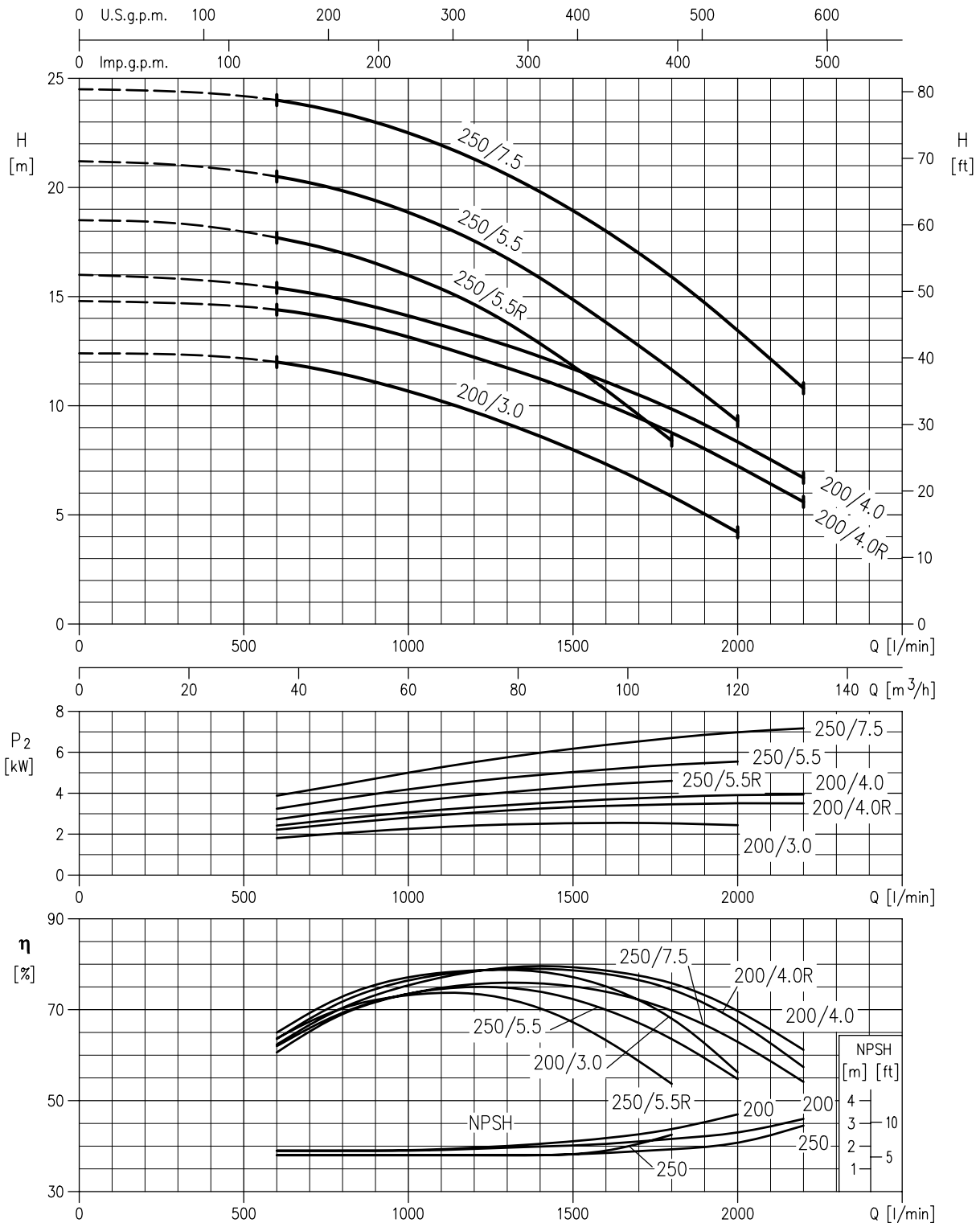

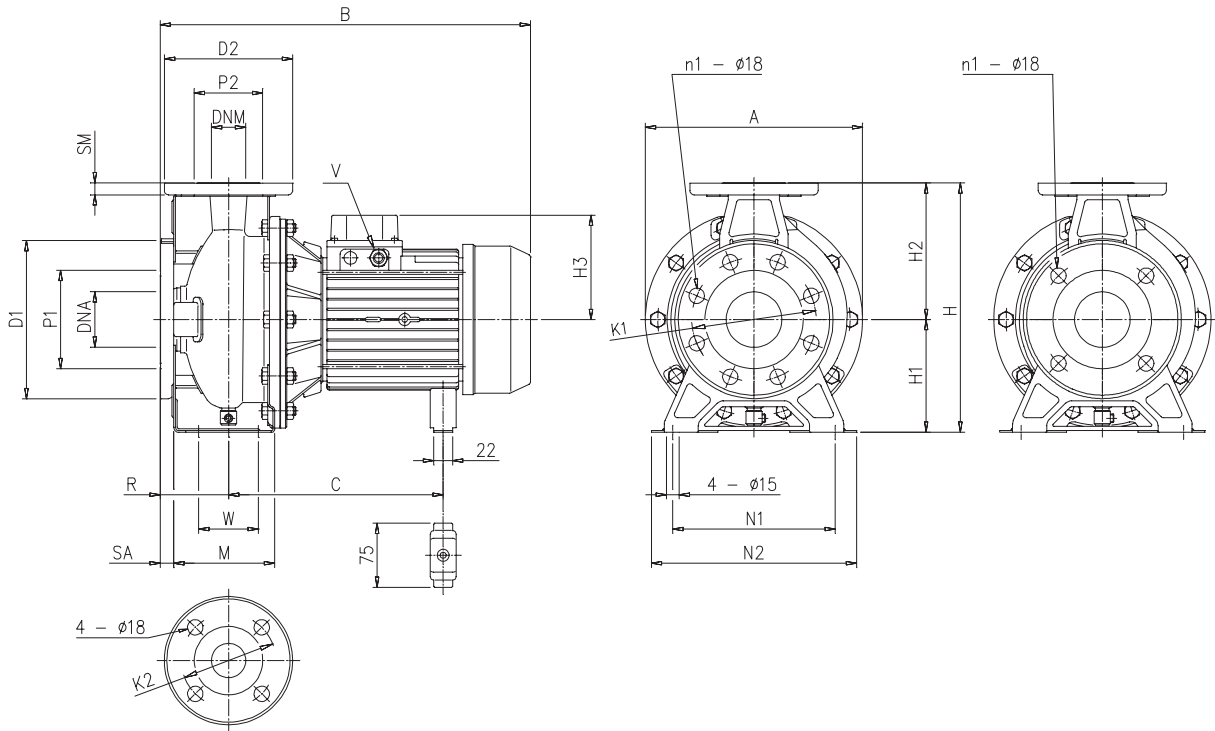

DIMENSIONAL TABLE

Pump type	Dimensions (mm)																										Weight (kg)
	∅ DNA	∅ P1	n1 [1] [2]	∅ K1	∅ D1	SA	∅ DNM	∅ P2	∅ K2	∅ D2	SM	H	H1	H2	H3 [3] [4]	R	W	N1	M	N2	A	B	C	V [3] [4]			
3M 32-125/1.1 (M)	50	96	4 -	125	165	16	32	76	100	140	14	252	112	140	122	139	80	70	140	114	190	213	408	231	PG 13,5 PG 13,5	19,6	
3M 32-160/1.5 (M)	50	96	4 -	125	165	16	32	76	100	140	14	292	132	160	122	139	80	70	190	118	240	254	408	231	PG 13,5 PG 13,5	22,5	
3M 32-160/2.2 (M)	50	96	4 -	125	165	16	32	76	100	140	14	292	132	160	122	139	80	70	190	118	240	254	408	231	PG 13,5 PG 13,5	24,6	
3M 32-200/3.0	50	96	4 -	125	165	16	32	76	100	140	14	340	160	180	122	-	80	70	190	119	240	296	433	256	PG 13,5	32,8	
3M 32-200/4.0	50	96	4 -	125	165	16	32	76	100	140	14	340	160	180	134	-	80	70	190	119	240	296	458	256	PG 16	39,5	
3M 32-200/5.5	50	96	4 -	125	165	16	32	76	100	140	14	340	160	180	153	-	80	70	190	119	240	296	477	276	PG 16	48,5	
3M 32-200/7.5	50	96	4 -	125	165	16	32	76	100	140	14	340	160	180	153	-	80	70	190	119	240	296	520	276	PG 16	57	
3M 40-125/1.5 (M)	65	116	4 -	145	185	16	40	81	110	150	14	252	112	140	122	139	80	70	160	114	210	213	408	231	PG 13,5 PG 13,5	20,1	
3M 40-125/2.2 (M)	65	116	4 -	145	185	16	40	81	110	150	14	252	112	140	122	139	80	70	160	114	210	213	408	231	PG 13,5 PG 13,5	22,7	
3M 40-160/3.0	65	116	4 -	145	185	16	40	81	110	150	14	292	132	160	122	-	80	70	190	118	240	254	433	255	PG 13,5	28	
3M 40-160/4.0	65	116	4 -	145	185	16	40	81	110	150	14	292	132	160	134	-	80	70	190	118	240	254	458	255	PG 16	35,1	
3M 40-160/5.5	65	116	4 -	145	185	16	40	81	110	150	14	340	160	180	153	-	100	70	212	139	265	296	497	278	PG 16	48,8	
3M 40-200/7.5	65	116	4 -	145	185	16	40	81	110	150	14	340	160	180	153	-	100	70	212	139	265	296	540	224	PG 16	56,2	
3M 40-200/11	65	116	4 -	145	185	16	40	81	110	150	14	340	160	180	181	-	100	70	212	139	265	296	577	224	PG 21	67,5	
3M 50-125/2.2 (M)	65	116	4 -	145	185	16	50	96	125	165	16	292	132	160	122	139	100	70	190	138	240	254	428	231	PG 13,5 PG 13,5	28,1	
3M 50-125/3.0	65	116	4 -	145	185	16	50	96	125	165	16	292	132	160	122	-	100	70	190	138	240	254	453	255	PG 13,5	28,6	
3M 50-125/4.0	65	116	4 -	145	185	16	50	96	125	165	16	292	132	160	134	-	100	70	190	138	240	254	478	255	PG 16	35,2	
3M 50-160/5.5	65	116	4 -	145	185	16	50	96	125	165	16	340	160	180	153	-	100	70	212	139	265	296	497	278	PG 16	49,1	
3M 50-160/7.5	65	116	4 -	145	185	16	50	96	125	165	16	340	160	180	153	-	100	70	212	139	265	296	540	224	PG 13	55,5	
3M 50-200/9.2	65	116	4 -	145	185	16	50	96	125	165	16	360	160	200	181	-	100	70	212	139	265	296	582	239	PG 21	61,7	
3M 50-200/11	65	116	4 -	145	185	16	50	96	125	165	16	360	160	200	181	-	100	70	212	139	265	296	582	239	PG 21	67,5	
3M 65-125/4	80	134	8 4	160	200	18	65	115	145	185	16	340	160	180	139	-	100	95	212	149,5	280	254	483	253	PG 16	40	
3M 65-125/5.5	80	134	8 4	160	200	18	65	115	145	185	16	340	160	180	150	-	100	95	212	149,5	280	254	496	275	PG 16	52	
3M 65-125/7.5	80	134	8 4	160	200	18	65	115	145	185	16	340	160	180	150	-	100	95	212	149,5	280	254	540	275	PG 16	58,5	
3M 65-160/7.5	80	134	8 4	160	200	18	65	115	145	185	16	360	160	200	150	-	100	95	212	149,5	280	296	540	275	PG 16	62	
3M 65-160/9.2	80	134	8 4	160	200	18	65	115	145	185	16	360	160	200	177,5	-	100	95	212	149,5	280	296	593	356	PG 21	67	
3M 65-160/11	80	134	8 4	160	200	18	65	115	145	185	16	360	160	200	177,5	-	100	95	212	149,5	280	296	593	356	PG 21	75,6	

[1] Standard
 [2] On request
 [3] Only for three phase
 [4] Only for single phase

3M (3LM) 15 ÷ 22 kW

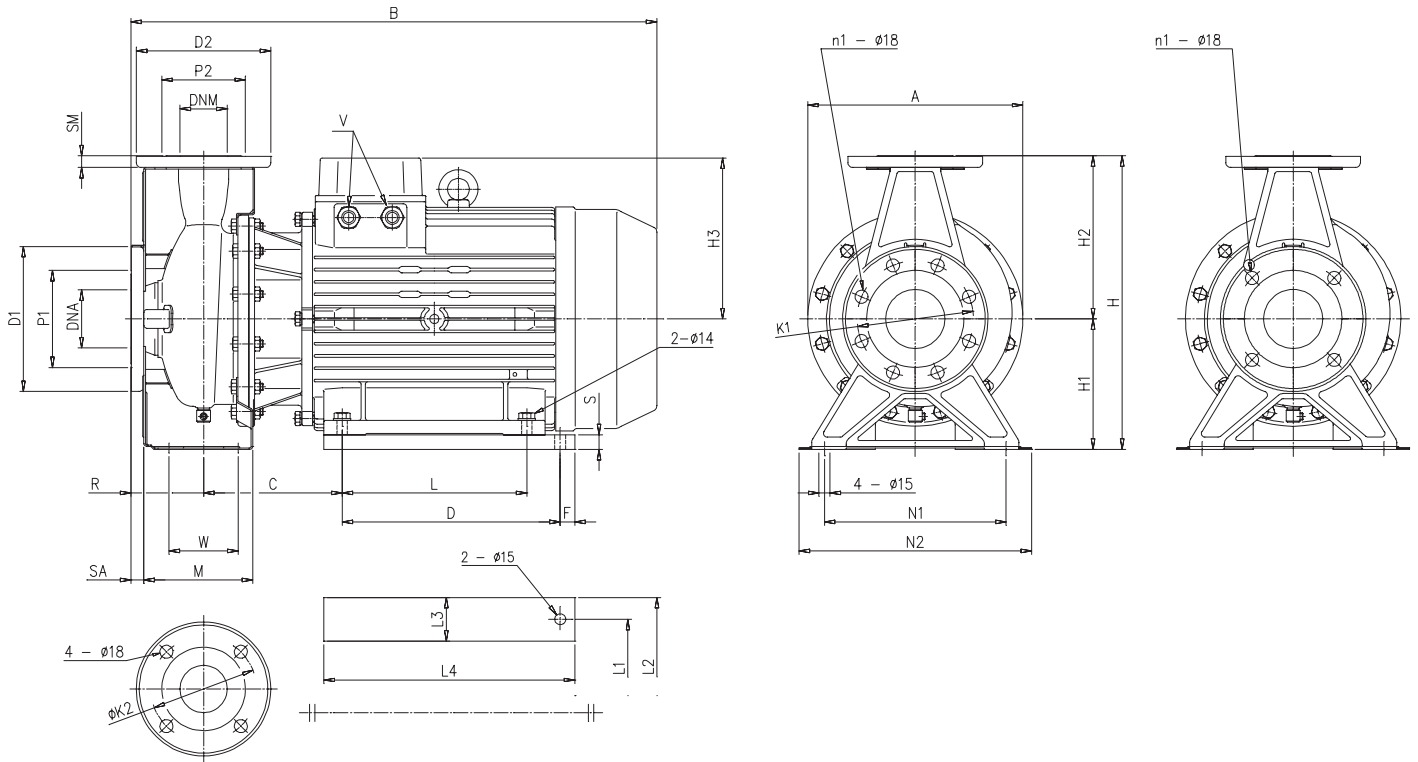

DIMENSIONAL TABLE

Pump type	Dimensions (mm)																												Weight (kg)					
	Ø DNA	Ø P1	n1 [1]	n1 [2]	Ø K1	Ø D1	SA	Ø DNM	Ø P2	Ø K2	Ø D2	SM	H	H1	H2	H3	R	W	N1	M	N2	A	B	L	L1	L2	L3	L4		C	D	F	V	S
3M 50-200/15	65	116	4	-	145	185	16	50	96	125	165	16	360	160	200	222	100	70	212	139	265	296	723,5	254	254	318	65	304	190,5	-	-	PG 21	-	96
3M 65-160/15	80	134	8	4	160	200	18	65	115	145	185	16	360	160	200	222	100	95	212	149,5	280	296	733	254	254	318	65	304	199,5	-	-	PG 21	-	93
3M 65-200/15	80	134	8	4	160	200	18	65	115	145	185	16	405	180	225	222	100	95	250	149,5	320	296	733	-	258	318	60	345	199,5	300	20	PG 21	20	114
3M 65-200/18.5	80	134	8	4	160	200	18	65	115	145	185	16	405	180	225	222	100	95	250	149,5	320	296	733	-	258	318	60	345	199,5	300	20	PG 21	20	127
3M 65-200/22	80	134	8	4	160	200	18	65	115	145	185	16	405	180	225	222	100	95	250	149,5	320	296	733	-	258	318	60	345	199,5	300	20	PG 21	20	136

3M (3LM)

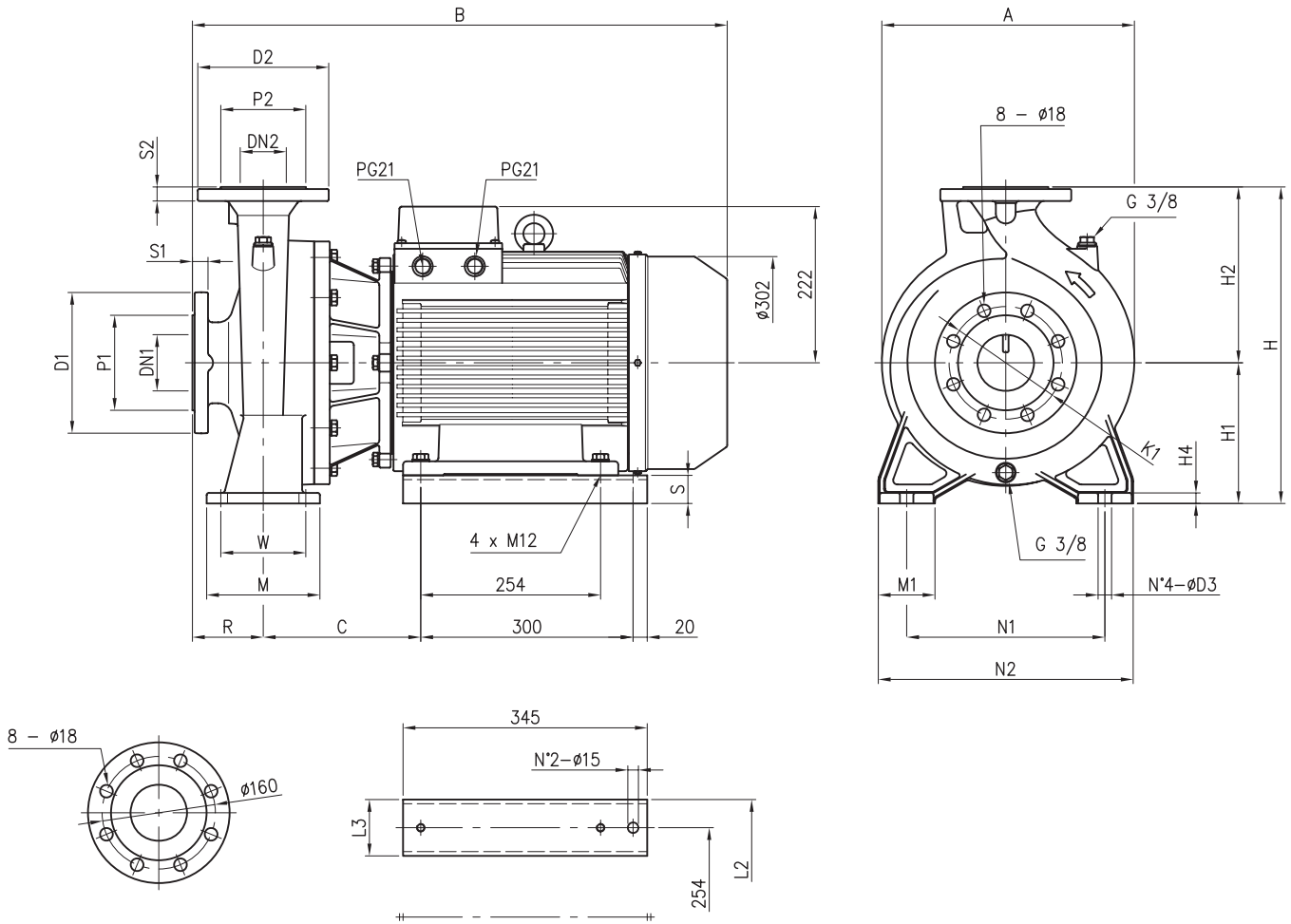

DIMENSIONAL TABLE

Pump type	Dimensions (mm)																										Weight (kg)
	DN1	P1	K1	D1	S1	DN2	P2	D2	S2	H	H1	H2	H4	R	W	N1	N2	M	M1	L2	L3	A	B	C	D	D3	
3LM(.) 80-160/15	100	155	180	225	24	80	135	200	22	405	180	225	13	125	95	250	320	125	65	314	60	317	758	199,5	20	15	130
3LM(.) 80-160/18.5	100	155	180	225	24	80	135	200	22	405	180	225	13	125	95	250	320	125	65	314	60	317	758	199,5	20	15	143

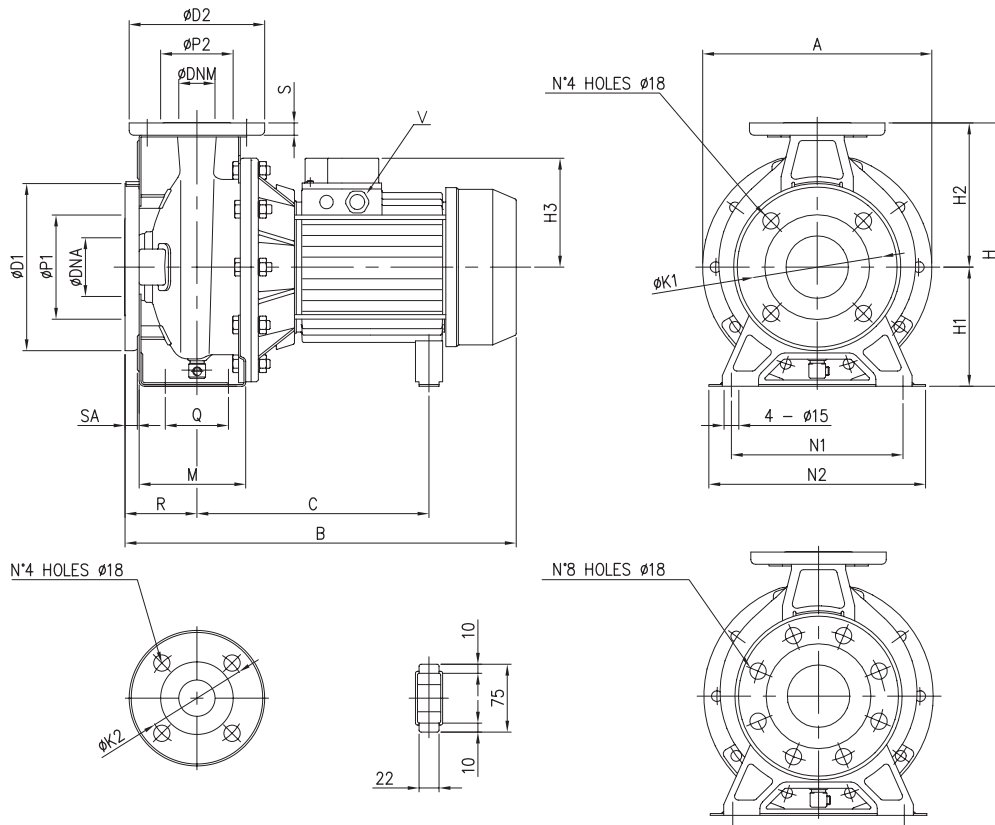

DIMENSIONAL TABLE

Pump type	Dimensions (mm)																			N. Holes		Weight (kg)				
	A	B	C	H	H1	H2	H3	M	N1	N2	Q	R	V	S	$\phi D1$	$\phi K1$	$\phi P1$	$\phi D2$	$\phi K2$	$\phi P2$	SA		ϕDNA	ϕDNM	Standard	On request
32-125/0.25	213	375	205	252	112	140	104	114	140	190	70	80	PG11	14	165	125	96	140	100	76	16	50	32	4	-	15
32-160/0.37R	254	395	222	292	132	160	117	118	190	240	70	80	PG11	14	165	125	96	140	100	76	16	50	32	4	-	20
32-160/0.37	254	395	222	292	132	160	117	118	190	240	70	80	PG11	14	165	125	96	140	100	76	16	50	32	4	-	20
32-200/0.55R	294	395	223	340	160	180	117	119	190	240	70	80	PG11	14	165	125	96	140	100	76	16	50	32	4	-	25
32-200/0.55	294	395	223	340	160	180	117	119	190	240	70	80	PG11	14	165	125	96	140	100	76	16	50	32	4	-	25
32-200/0.75	294	408	232	340	160	180	122	119	190	240	70	80	PG13.5	14	165	125	96	140	100	76	16	50	32	4	-	29,3
40-125/0.37R	213	375	205	252	112	140	104	114	160	210	70	80	PG11	14	185	145	116	150	110	81	16	65	40	4	-	15
40-125/0.37	213	375	205	252	112	140	104	114	160	210	70	80	PG11	14	185	145	116	150	110	81	16	65	40	4	-	15
40-160/0.55R	254	395	222	292	132	160	117	118	190	240	70	80	PG11	14	185	145	116	150	110	81	16	65	40	4	-	20
40-160/0.55	254	395	222	292	132	160	117	118	190	240	70	80	PG11	14	185	145	116	150	110	81	16	65	40	4	-	20
40-200/1.1R	294	428	232	340	160	180	122	139	212	265	70	100	PG13.5	14	185	145	116	150	110	81	16	65	40	4	-	30
40-200/1.1	294	428	232	340	160	180	122	139	212	265	70	100	PG13.5	14	185	145	116	150	110	81	16	65	40	4	-	30
40-200/1.5	294	428	232	340	160	180	122	139	212	265	70	100	PG13.5	14	185	145	116	150	110	81	16	65	40	4	-	32,2
50-125/0.55R	254	415	222	292	132	160	117	138	190	240	70	100	PG11	16	185	145	116	165	125	96	16	65	50	4	-	20
50-125/0.55	254	415	222	292	132	160	117	138	190	240	70	100	PG11	16	185	145	116	165	125	96	16	65	50	4	-	20
50-160/1.1R	296	428	232	340	160	180	122	139	212	265	70	100	PG13.5	16	185	145	116	165	125	96	16	65	50	4	-	30
50-160/1.1	296	428	232	340	160	180	122	139	212	265	70	100	PG13.5	16	185	145	116	165	125	96	16	65	50	4	-	30
50-200/1.5R	296	428	232	360	160	200	122	139	212	265	70	100	PG13.5	16	185	145	116	165	125	96	16	65	50	4	-	30
50-200/1.5	296	428	232	360	160	200	122	139	212	265	70	100	PG13.5	16	185	145	116	165	125	96	16	65	50	4	-	30
50-200/2.2	296	478	256	360	160	200	134	139	212	265	70	100	PG16	16	185	145	116	165	125	96	16	65	50	4	-	31,8
65-125/0.55	254	415	219	340	160	180	117	150	212	280	95	100	PG11	16	200	160	134	185	145	115	18	80	65	8	4	24,9
65-125/0.75	254	427	230	340	160	180	124	150	212	280	95	100	PG13.5	16	200	160	134	185	145	115	18	80	65	8	4	29,8
65-125/1.1	254	427	230	340	160	180	124	150	212	280	95	100	PG13.5	16	200	160	134	185	145	115	18	80	65	8	4	30,1
65-160/1.1	296	427	230	360	160	200	124	150	212	280	95	100	PG13.5	16	200	160	134	185	145	115	18	80	65	8	4	32,8
65-160/1.5	296	427	230	360	160	200	124	150	212	280	95	100	PG13.5	16	200	160	134	185	145	115	18	80	65	8	4	34,6
65-160/2.2	296	483	253	360	160	200	139	150	212	280	95	100	PG16	16	200	160	134	185	145	115	18	80	65	8	4	39,8
65-200/2.2R	296	483	253	405	180	225	139	150	250	320	95	100	PG16	16	200	160	134	185	145	115	18	80	65	8	4	46,5
65-200/2.2	296	483	253	405	180	225	139	150	250	320	95	100	PG16	16	200	160	134	185	145	115	18	80	65	8	4	46,7
65-200/3.0	296	483	253	405	180	225	139	150	250	320	95	100	PG16	16	200	160	134	185	145	115	18	80	65	8	4	51,3

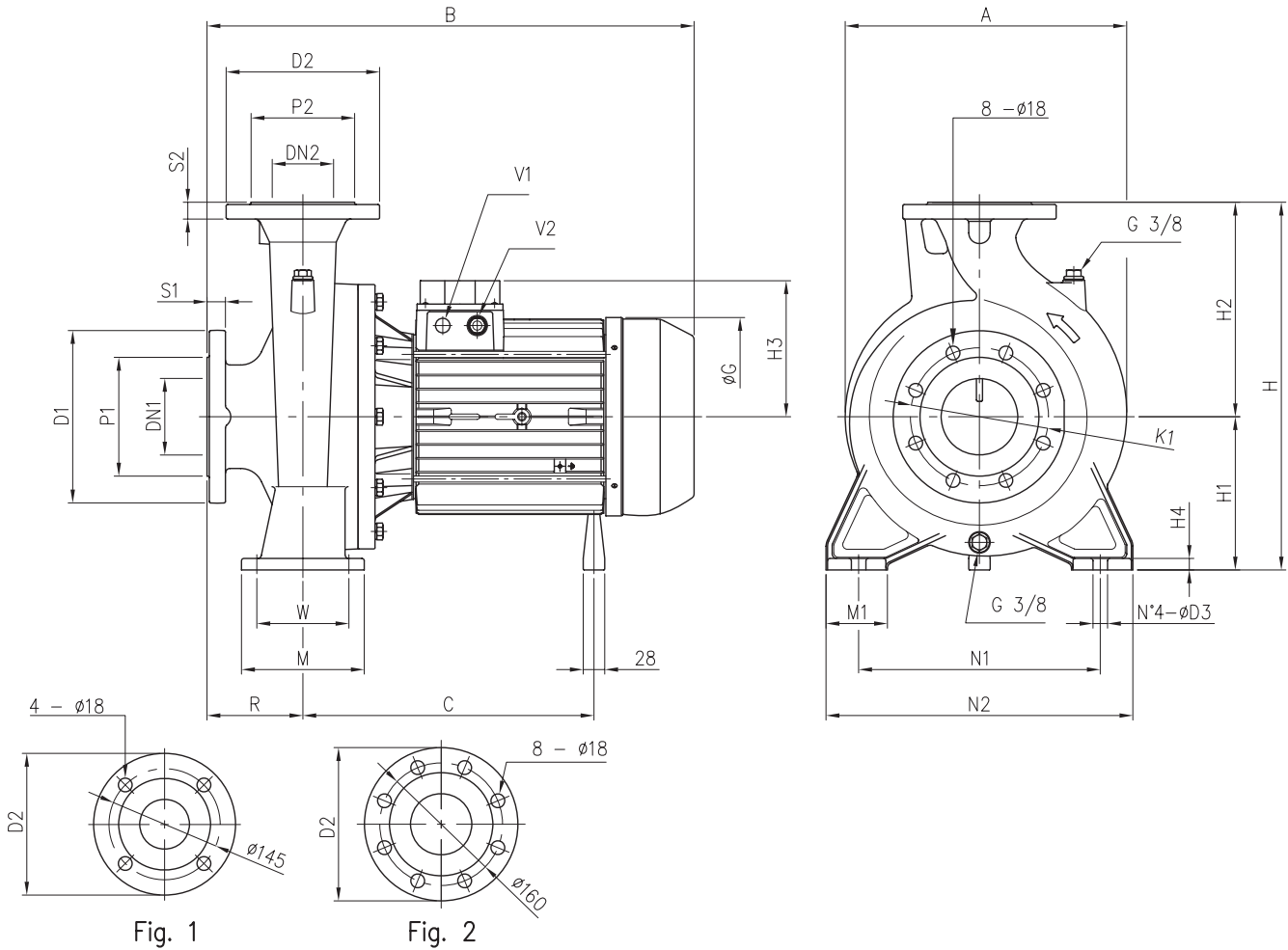

DIMENSIONAL TABLE

Pump type	Dimensions (mm)																							Weight (kg)						
	DN1	P1	K1	D1	S1	DN2	Fig.	P2	D2	S2	H	H1	H2	H3	H4	R	W	N1	N2	M	M1	A	B		C	G	D3	D5	V1	V2
3LM4(.) 65-250/4	80	135	160	200	22	65	1	120	185	20	450	200	250	150	15	100	120	280	360	160	80	357	516	295	216	19	M10	PG13,5	PG16	82
3LM4(.) 65-250/5.5	80	135	160	200	22	65	1	120	185	20	450	200	250	178	15	100	120	280	360	160	80	357	610	380	255	19	M10	PG13,5	PG21	94,5
3LM4(.) 80-160/1.5	100	155	180	225	24	80	2	135	200	22	405	180	225	124	13	125	95	250	320	125	65	317	452	230	172	15	M8	-	PG13,5	55
3LM4(.) 80-160/2.2R	100	155	180	225	24	80	2	135	200	22	405	180	225	139	13	125	95	250	320	125	65	317	508	253	187	15	M10	-	PG16	60
3LM4(.) 80-160/2.2	100	155	180	225	24	80	2	135	200	22	405	180	225	139	13	125	95	250	320	125	65	317	508	253	187	15	M10	-	PG16	60,5
3LM4(.) 80-200/3	100	155	180	225	24	80	2	135	200	22	430	180	250	139	13	125	95	280	345	125	65	354	530	275	187	15	M10	-	PG16	76,5
3LM4(.) 80-200/4R	100	155	180	225	24	80	2	135	200	22	430	180	250	150	13	125	95	280	345	125	65	354	541	295	216	15	M10	PG13,5	PG16	85,5
3LM4(.) 80-200/4	100	155	180	225	24	80	2	135	200	22	430	180	250	150	13	125	95	280	345	125	65	354	541	295	216	15	M10	PG13,5	PG16	86
3LM4(.) 80-250/5.5R	100	155	180	225	24	80	2	135	200	22	480	200	280	178	15	125	120	315	400	160	80	367	635	380	255	19	M10	PG13,5	PG21	98,5
3LM4(.) 80-250/5.5	100	155	180	225	24	80	2	135	200	22	480	200	280	178	15	125	120	315	400	160	80	367	635	380	255	19	M10	PG13,5	PG21	99
3LM4(.) 80-250/5.5	100	155	180	225	24	80	2	135	200	22	480	200	280	178	15	125	120	315	400	160	80	367	635	380	255	19	M10	PG13,5	PG21	104,5

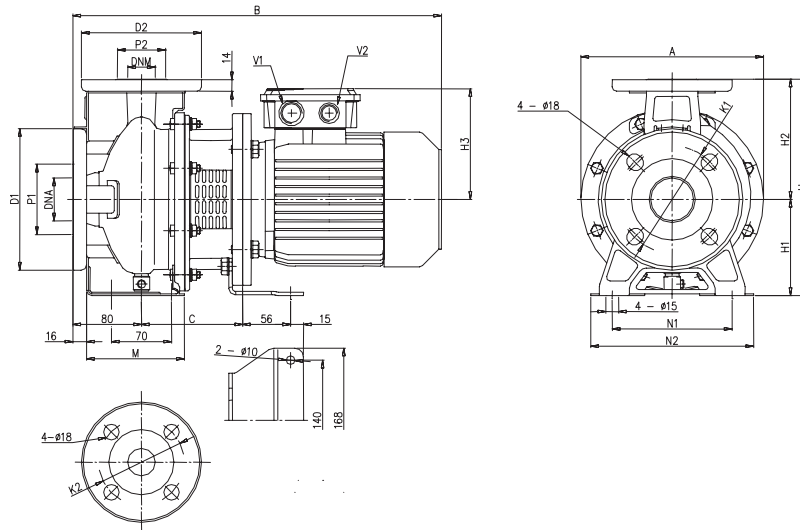

DIMENSIONAL TABLE

Pump type	Dimensions (mm)																				Weight (kg)	
	Ø DNA	Ø P1	Ø K1	Ø D1	Ø DNM	Ø P2	Ø K2	Ø D2	H	H1	H2	H3		N1	M	N2	A	B	C	V1		V2
3S 32-125/1.1 (M)	50	96	125	165	32	76	100	140	252	112	140	[1]	[2]	140	114	190	213	430	118	PG16	PG13,5	23,1
3S 32-160/1.5 (M)	50	96	125	165	32	76	100	140	292	132	160	138	160	190	118	240	254	477	130	PG16	pG13,5	28,5
3S 32-160/2.2 (M)	50	96	125	165	32	76	100	140	292	132	160	138	160	190	118	240	254	477	130	PG16	PG13,5	32,4
3S 40-125/2.2 (M)	65	116	145	185	40	81	110	150	252	112	140	138	160	160	114	210	213	477	130	PG16	PG13,5	26,5
3S 40-125/2.2 (M)	65	116	145	185	40	81	110	150	252	112	140	138	160	160	114	210	213	477	130	PG16	PG13,5	29,6
3S 50-125/2.2 (M)	65	116	145	185	50	95	125	165	292	132	160	138	160	190	138	240	254	497	130	PG16	PG13,5	32,9

[1] Only for three phase
[2] Only for single phase

3S (3LS) 3 ÷ 4 kW

2 POLES

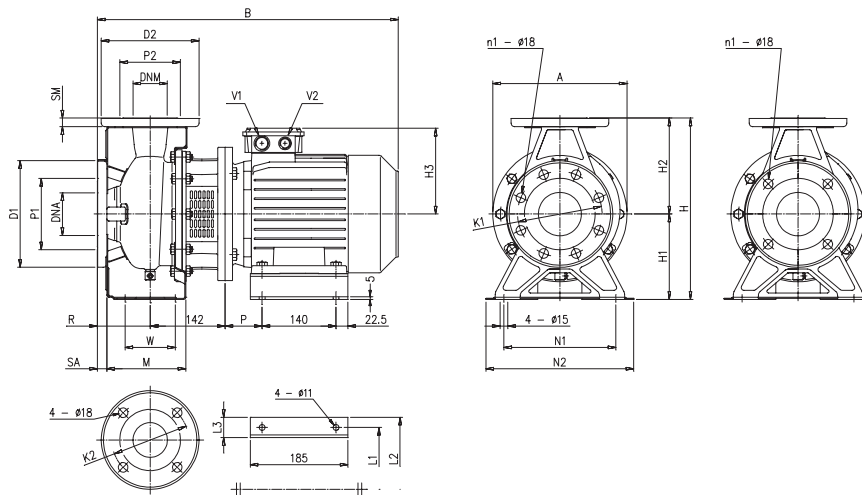

DIMENSIONAL TABLE

Pump type	Dimensions (mm)																							Weight (kg)						
	Ø DNA	Ø P1	n1	Ø K1	Ø D1	SA	Ø DNM	Ø P2	Ø K2	Ø D2	SM	H	H1	H2	H3	R	W	N1	M	N2	A	B	L1		L2	L3	P	V1	V2	
3S 32-200/3.0	50	96	4	-	125	165	16	32	76	100	140	14	340	160	180	145	80	70	190	119	240	294	528	160	202	42	63	PG 16	PG 13,5	43,4
3S 32-200/4.0	50	96	4	-	125	165	16	32	76	100	140	14	340	160	180	161	80	70	190	119	240	294	550	190	228	38	70	PG 16	PG 13,5	45,9
3S 65-125/4.0	80	134	8	4	160	200	18	65	115	145	185	16	340	160	180	161	100	95	212	149,5	280	254	615	190	228	38	70	PG16	PG 13,5	47

[1] Standard
[2] On request

3S (3LS) 11 ÷ 15 kW

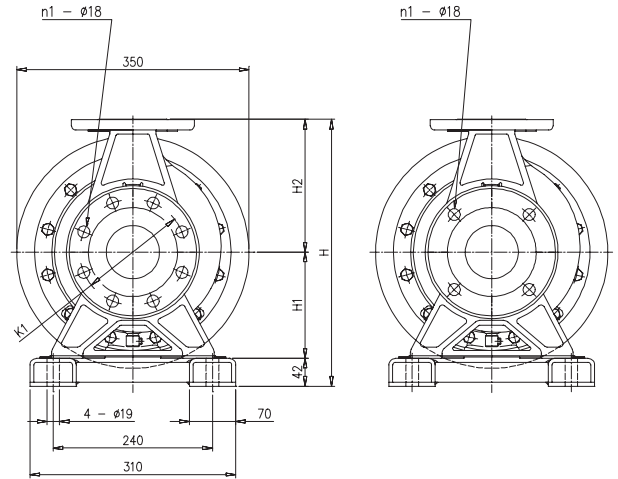
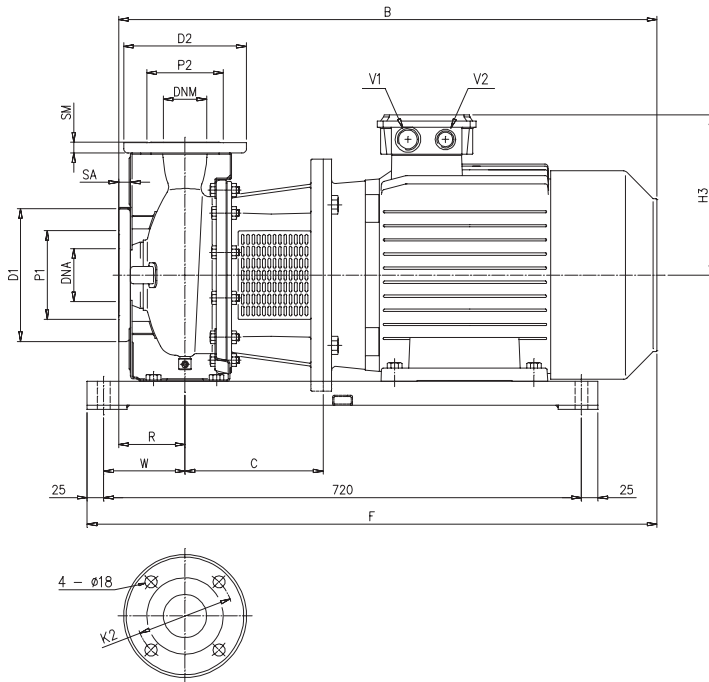

DIMENSIONAL TABLE

Pump type	Dimensions (mm)																					Weight (kg)		
	∅ DNA	∅ P1	n1		∅ K1	∅ D1	∅ SA	∅ DNM	∅ P2	∅ K2	∅ D2	SM	H	H1	H2	H3	R	W	B	C	F		V1	V2
3S 40-200/11	65	115	4	-	145	185	16	40	80	110	150	14	382	160	180	250	100	110	801	198	836	PG 29	PG 29	107
3S 50-200/11	65	115	4	-	145	185	16	50	95	125	165	16	402	160	200	250	100	110	801	198	836	PG 29	PG 29	107
3S 50-200/15	65	115	4	-	145	185	16	50	95	125	165	16	402	160	200	250	100	110	801	198	836	PG 29	PG 29	131
3S 65-160/11	80	134	8	4	160	200	18	65	115	145	185	16	402	160	200	246	100	122,5	801	198	849	PG 29	PG 29	76
3S 65-160/15	80	134	8	4	160	200	18	65	115	145	185	16	402	160	200	246	100	122,5	811	208	859	PG 29	PG 29	104

[1] As standard
[2] On request

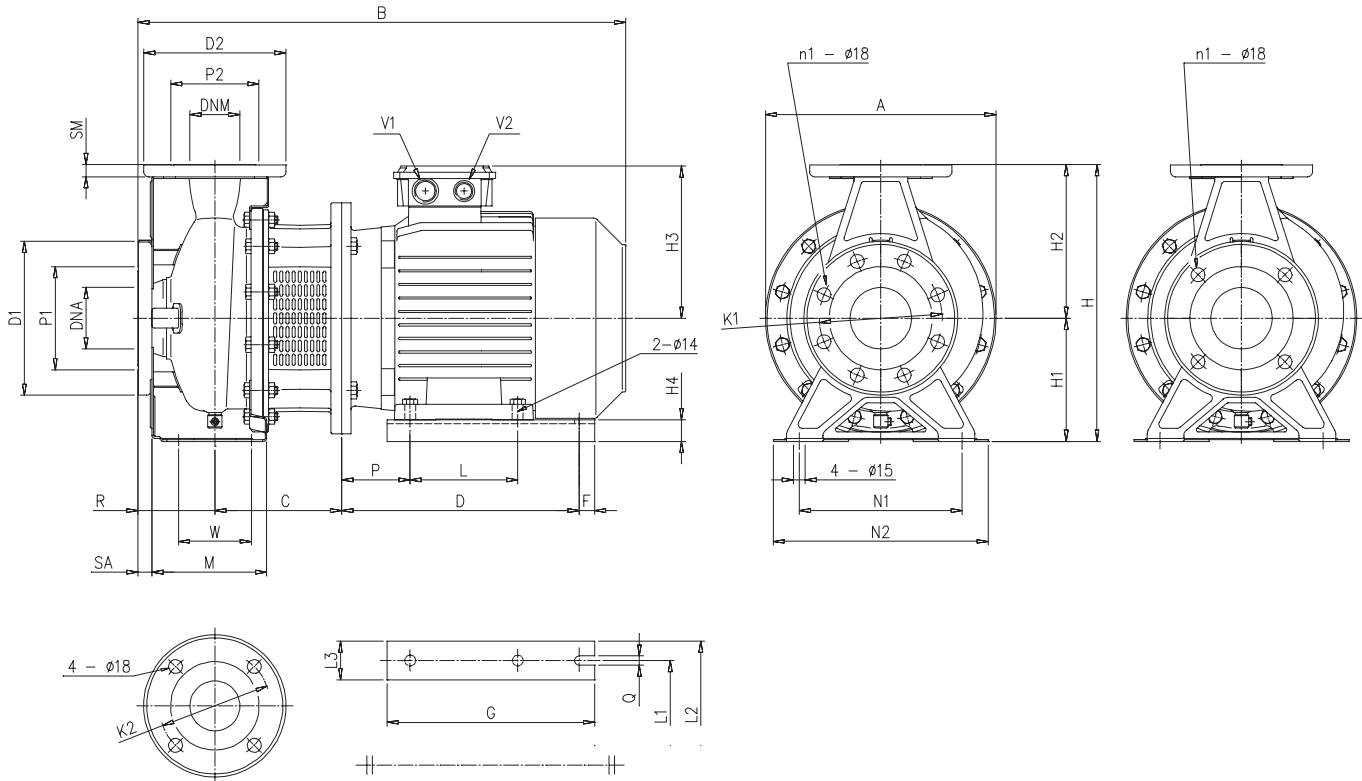

DIMENSIONAL TABLE

Pump type	Dimensions (mm)																										Weight (kg)										
	Ø DNA	Ø P1	n1 [1] [2]	Ø K1	Ø D1	SA	Ø DNM	Ø P2	Ø K2	Ø D2	SM	H	H1	H2	H3	H4	R	W	N1	M	N2	A	B	C	D	F		L	L1	L2	L3	G	Q	P	V	V2	
3S 32-200/5.5	50	96	4	-	125	165	16	32	76	100	140	14	340	160	180	205	28	80	70	190	119	240	300	615	165	314	15	-	216	266	50	270	12	-	PG21	PG21	62,8
3S 32-200/7.5	50	96	4	-	125	165	16	32	76	100	140	14	340	160	180	205	28	80	70	190	119	240	300	615	165	314	15	-	216	266	50	270	12	-	PG21	PG21	74,6
3S 40-160/3.0	65	116	4	-	145	185	16	40	81	110	150	14	292	132	160	145	32	80	70	190	118	240	254	528	142	246	15	-	160	200	40	220	12	-	PG16	PG13,5	39
3S 40-160/4.0	65	116	4	-	145	185	16	40	81	110	150	14	292	132	160	161	20	80	70	190	118	240	254	550	142	253	15	-	190	240	50	220	12	-	PG16	PG13,5	41,5
3S 40-200/5.5	65	116	4	-	145	185	16	40	81	110	150	14	340	160	180	205	28	100	70	212	139	265	300	635	165	314	15	-	216	266	50	270	12	-	PG21	PG21	63,2
3S 40-200/7.5	65	116	4	-	145	185	16	40	81	110	150	14	340	160	180	205	28	100	70	212	139	265	300	635	165	314	15	-	216	266	50	270	12	-	PG21	PG21	69,6
3S 50-125/3.0	65	116	4	-	145	185	16	50	96	125	165	16	292	132	160	145	32	100	70	190	138	240	254	548	142	246	15	-	160	200	40	220	12	-	PG16	PG13,5	42
3S 50-125/4.0	65	116	4	-	145	185	16	50	96	125	165	16	292	132	160	161	20	100	70	190	138	240	254	570	142	253	15	-	190	240	50	220	12	-	PG16	PG13,5	42,5
3S 50-160/5.5	65	116	4	-	145	185	16	50	96	125	165	16	340	160	180	205	28	100	70	212	139	265	300	635	165	314	15	-	216	266	50	270	12	-	PG21	PG21	63,8
3S 50-160/7.5	65	116	4	-	145	185	16	50	96	125	165	16	340	160	180	205	28	100	70	212	139	265	300	635	165	314	15	-	216	266	50	270	12	-	PG21	PG21	69,6
3S 50-200/9.2	65	116	4	-	145	185	16	50	96	125	165	16	360	160	200	205	28	100	70	212	139	265	300	673	165	314	15	-	216	266	50	270	12	-	PG21	PG21	79,7
3S 65-125/5.5	80	134	8	4	160	200	18	65	115	185	185	16	340	160	180	198	28	100	95	212	149,5	280	300	635	165	314	15	-	216	266	50	270	12	-	PG21	PG21	60
3S 65-125/7.5	80	134	8	4	160	200	18	65	115	185	185	16	340	160	180	198	28	100	95	212	149,5	280	300	635	165	314	15	-	216	266	50	270	12	-	PG21	PG21	67
3S 65-160/7.5	80	134	8	4	160	200	18	65	115	185	185	16	360	160	200	198	28	100	95	212	149,5	280	300	635	165	314	15	-	216	266	50	270	12	-	PG21	PG21	70
3S 65-160/9.2	80	134	8	4	160	200	18	65	115	185	185	16	360	160	200	198	28	100	95	212	149,5	280	300	673	165	314	15	-	216	266	50	270	12	-	PG21	PG21	77
3S 65-200/15	80	134	8	4	160	200	18	65	115	185	185	16	405	180	225	246	20	100	95	250	149,5	320	350	811	208	413	20	-	254	314	60	350	14	-	PG29	PG29	128
3S 65-200/18.5	80	134	8	4	160	200	18	65	115	185	185	16	405	180	225	246	20	100	95	250	149,5	320	350	855	208	413	20	-	254	314	60	350	14	-	PG29	PG29	141
3S 65-200/22	80	134	8	4	160	200	18	65	115	185	185	16	405	180	225	266	-	100	95	250	149,5	320	350	910	208	-	-	241	279	330	83	-	-	121	PG29	PG29	160

[1] Standard
[2] On request

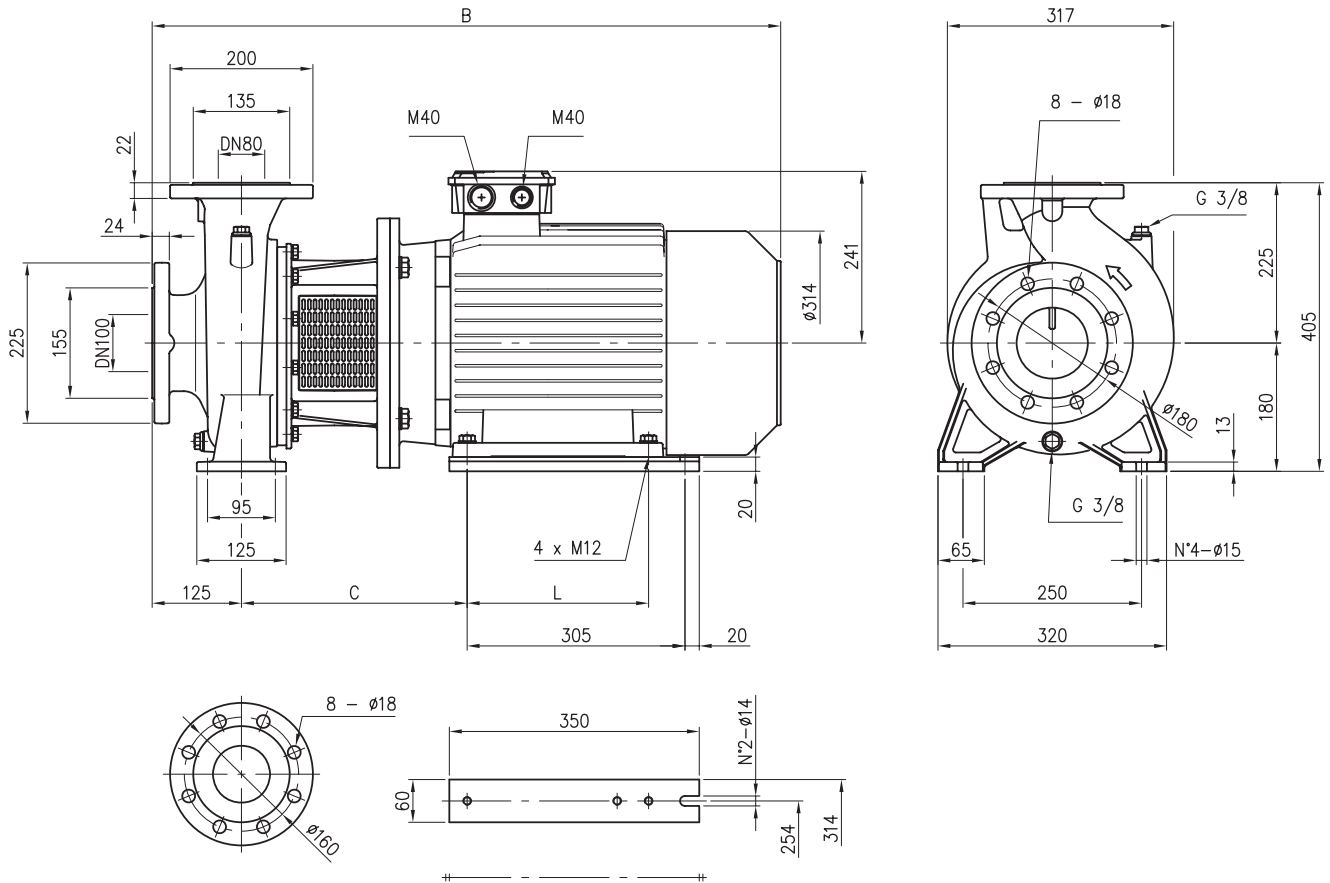

DIMENSIONAL TABLE

Pump type	Dimensions (mm)			Weight (kg)
	L	B	C	
3LS(.) 80-160/11	210	826	306	135
3LS(.) 80-160/15R	210	836	316	147
3LS(.) 80-160/15	210	836	316	147
3LS(.) 80-160/18.5	254	880	316	155

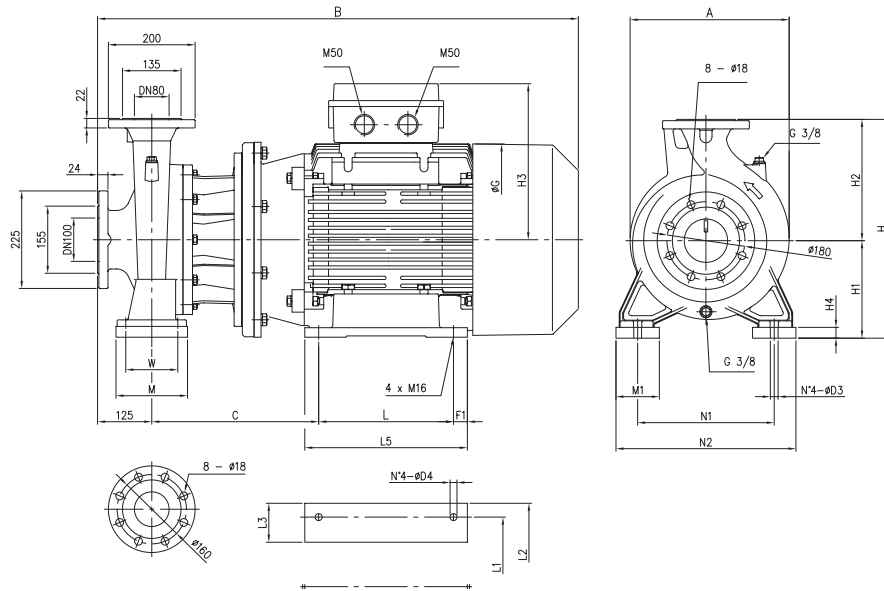

DIMENSIONAL TABLE

Pump type	Dimensions (mm)																				Weight (kg)		
	H	H1	H2	H3	H4	W	N1	N2	M	M1	L	L1	L2	L3	L5	A	B	C	F1	G		D3	D4
3S 80-200/30	450	200	250	341	20	95	280	360	130	80	305	318	400	78	360	354	1002	341	27,5	393	14	22	306
3S 80-200/37	450	200	250	341	20	95	280	360	130	80	305	318	400	78	360	354	1002	341	27,5	393	14	22	325
3S 80-250/45	505	225	280	360	25	120	315	415	165	100	311	356	420	90	375	367	1109	385	32	442	18	16	401

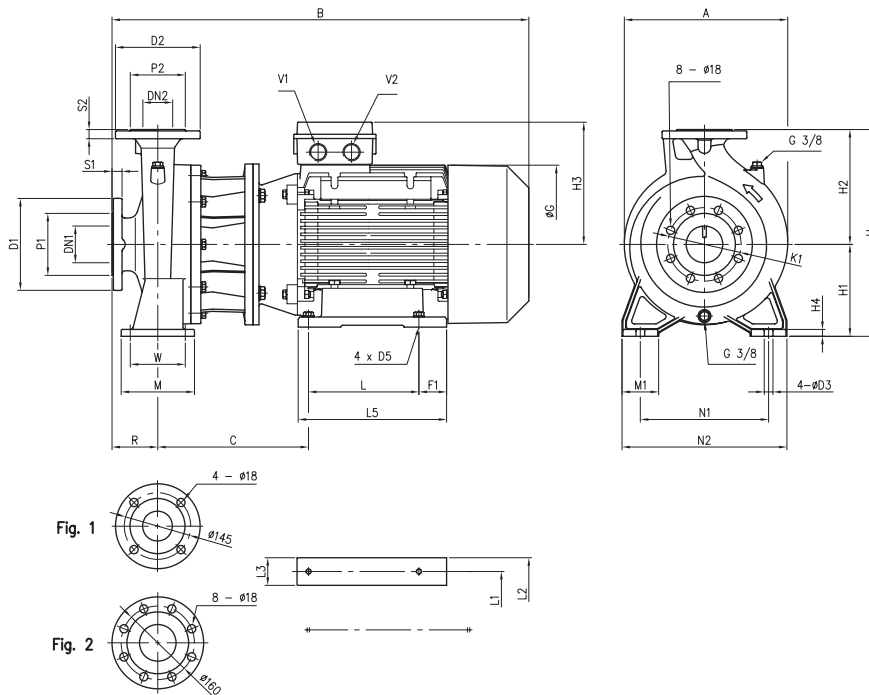
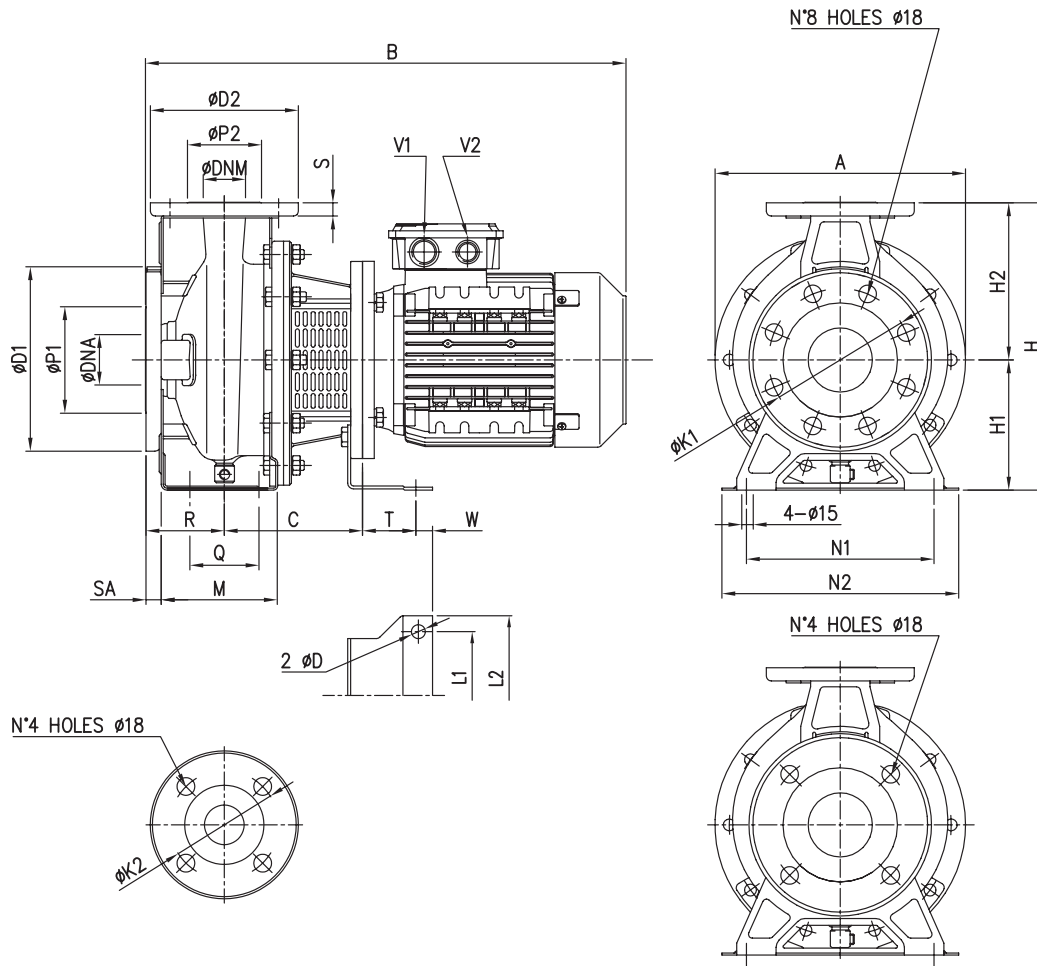

Fig. 1

Fig. 2

DIMENSIONAL TABLE

Pump type	Dimensions (mm)																										Weight (kg)									
	DN1	P1	K1	D1	S1	DN2	Fig.	P2	D2	S2	H	H1	H2	H3	H4	R	W	N1	N2	M	M1	L	L1	L2	L3	L5		A	B	C	F1	G	D3	D5	V1	V2
3LS(.) 65-250/30	80	135	160	200	22	65	1	120	185	20	450	200	250	341	15	100	120	280	360	160	80	305	318	400	78	360	357	977	341	27,5	393	19	M16	M50	M50	303
3LS(.) 65-250/37	80	135	160	200	22	65	1	120	185	20	450	200	250	341	15	100	120	280	360	160	80	305	318	400	78	360	357	977	341	27,5	393	19	M16	M50	M50	320
3LS(.) 80-200/22	100	155	180	225	24	80	2	135	200	22	430	180	250	266	13	125	95	280	345	125	65	241	279	330	66	324	354	935	329	60,5	345	15	M12	M40	M40	200
3LS(.) 80-250/37	100	155	180	225	24	80	2	135	200	22	480	200	280	341	15	125	120	315	400	160	80	305	318	400	78	360	367	1030	369	27,5	393	19	M16	M50	M50	335



DIMENSIONAL TABLE

Pump type	Dimensions (mm)																				N. Holes		Weight (kg)								
	A	B	C	D	H	H1	H2	L1	L2	M	N1	N2	Q	R	S	T	W	Ø D1	Ø K1	Ø P1	Ø D2	Ø K2		Ø P2	SA	Ø DNA	Ø DNM	V1	V2	Standard	On request
32-125/0.25	213	401	108	8	252	112	140	112	140	114	140	190	70	80	14	45	15	165	125	96	140	100	76	16	50	32	PG11	PG13,5	4	-	15,5
32-160/0.37R	254	401	108	8	292	132	160	112	140	118	190	240	70	80	14	45	15	165	125	96	140	100	76	16	50	32	PG11	PG13,5	4	-	20,7
32-160/0.37	254	401	108	8	292	132	160	112	140	118	190	240	70	80	14	45	15	165	125	96	140	100	76	16	50	32	PG11	PG13,5	4	-	20,7
32-200/0.55R	296	435	118	10	340	160	180	140	168	119	190	240	70	80	14	56	15	165	125	96	140	100	76	16	50	32	PG13,5	PG16	4	-	28,9
32-200/0.55	296	435	118	10	340	160	180	140	168	119	190	240	70	80	14	56	15	165	125	96	140	100	76	16	50	32	PG13,5	PG16	4	-	28,9
32-200/0.75	296	435	118	10	340	160	180	140	168	119	190	240	70	80	14	56	15	165	125	96	140	100	76	16	50	32	PG13,5	PG16	4	-	30,1
40-125/0.37R	213	401	118	8	252	112	140	112	140	114	160	210	70	80	14	45	15	185	145	116	150	110	81	16	65	40	PG11	PG13,5	4	-	17,6
40-125/0.37	213	401	118	8	252	112	140	112	140	114	160	210	70	80	14	45	15	185	145	116	150	110	81	16	65	40	PG11	PG13,5	4	-	17,6
40-160/0.55R	254	435	118	10	292	132	160	140	168	118	190	240	70	80	14	56	15	185	145	116	150	110	81	16	65	40	PG13,5	PG16	4	-	23,2
40-160/0.55	254	435	118	10	292	132	160	140	168	118	190	240	70	80	14	56	15	185	145	116	150	110	81	16	65	40	PG13,5	PG16	4	-	23,2
40-200/1.1R	294	487	130	10	340	160	180	140	168	139	212	265	70	100	14	56	15	185	145	116	150	110	81	16	65	40	PG13,5	PG16	4	-	33,3
40-200/1.1	294	487	130	10	340	160	180	140	168	139	212	265	70	100	14	56	15	185	145	116	150	110	81	16	65	40	PG13,5	PG16	4	-	33,3
40-200/1.5	294	512	130	10	340	160	180	140	168	139	212	265	70	100	14	56	15	185	145	116	150	110	81	16	65	40	PG13,5	PG16	4	-	35,5
50-125/0.55R	254	452	118	10	292	132	160	140	168	138	190	240	70	100	16	56	15	185	145	116	165	125	96	16	65	50	PG13,5	PG16	4	-	23,5
50-125/0.55	254	452	118	10	292	132	160	140	168	138	190	240	70	100	16	56	15	185	145	116	165	125	96	16	65	50	PG13,5	PG16	4	-	23,5
50-160/1.1R	296	487	130	10	340	160	180	140	168	139	212	265	70	100	16	56	15	185	145	116	165	125	96	16	65	50	PG13,5	PG16	4	-	34,0
50-160/1.1	296	487	130	10	340	160	180	140	168	139	212	265	70	100	16	56	15	185	145	116	165	125	96	16	65	50	PG13,5	PG16	4	-	34,0
50-200/1.5R	296	512	130	10	360	160	200	140	168	139	212	265	70	100	16	56	15	185	145	116	165	125	96	16	65	50	PG13,5	PG16	4	-	30,0
50-200/1.5	296	512	130	10	360	160	200	140	168	139	212	265	70	100	16	56	15	185	145	116	165	125	96	16	65	50	PG13,5	PG16	4	-	30,0
65-125/0.55	254	450	118	10	340	160	180	140	168	150	212	280	90	100	16	56	15	200	160	134	185	145	115	18	80	65	PG16	PG13,5	8	4	30,8
65-125/0.75	254	450	118	1	340	160	180	140	168	150	212	280	90	100	16	56	15	200	160	134	185	145	115	18	80	65	PG16	PG13,5	8	4	32
65-125/1.1	254	497	130	10	340	160	180	140	168	150	212	280	90	100	16	56	15	200	160	134	185	145	115	18	80	65	PG16	PG13,5	8	4	36
65-160/1.1	296	497	130	10	360	160	200	140	168	150	212	280	90	100	16	56	15	200	160	134	185	145	115	18	80	65	PG16	PG13,5	8	4	40,1
65-160/1.5	296	497	130	10	360	160	200	140	168	150	212	280	90	100	16	56	15	200	160	134	185	145	115	18	80	65	PG16	PG13,5	8	4	41,2

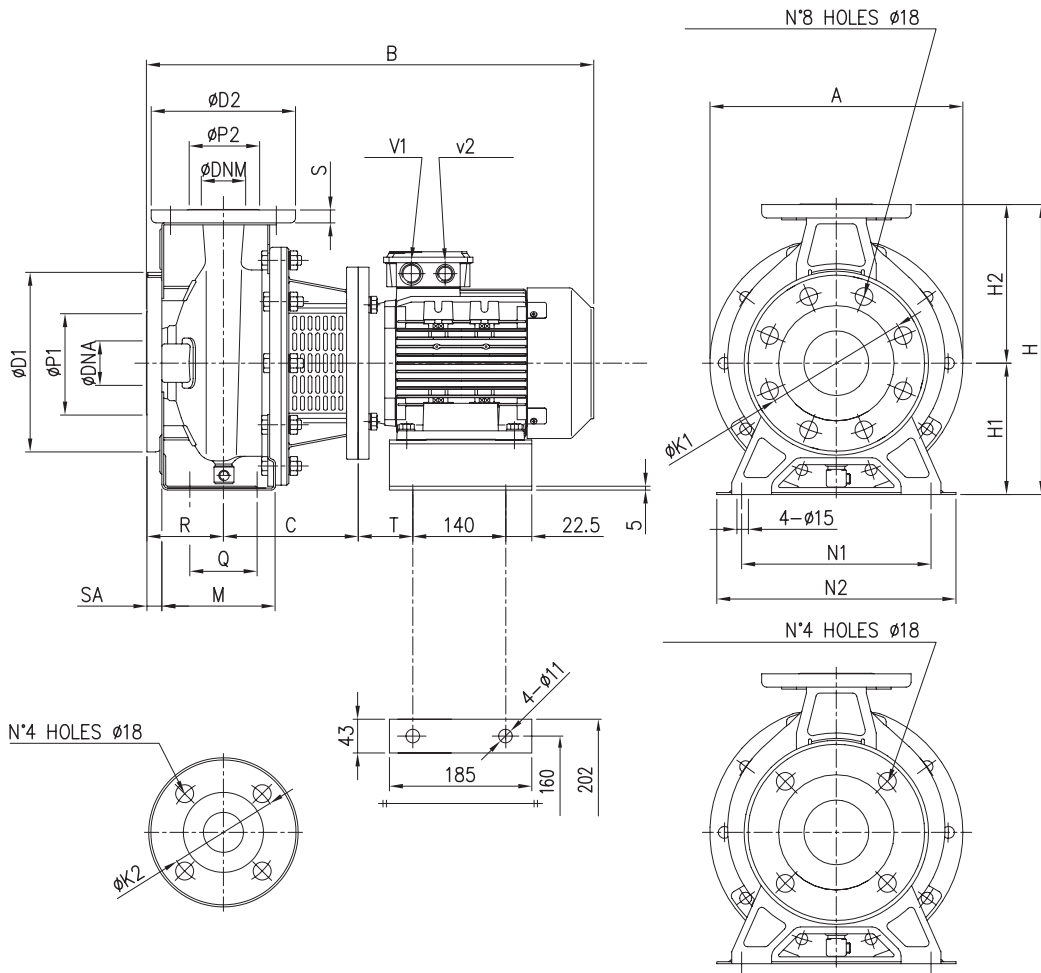

DIMENSIONAL TABLE

Pump type	Dimensions (mm)																						No. Holes		Weight (kg)		
	A	B	C	H	H1	H2	M	N1	N2	Q	R	S	T	$\phi D1$	$\phi K1$	$\phi P1$	$\phi D2$	$\phi K2$	$\phi P2$	SA	ϕDNA	ϕDNM	V1	V2		Standard	On request
50-200/2.2	296	555	142	360	160	200	115	212	265	70	100	16	70	185	145	116	165	125	96	16	65	50	PG16	PG13,5	4	-	63,7
65-160/2.2	296	548	142	360	160	200	145	212	280	95	100	16	63	200	160	134	185	145	115	18	80	65	PG16	PG13,5	8	4	51,7
65-200/2.2R	296	548	142	405	180	225	145	250	320	95	100	16	63	200	160	134	185	145	115	18	80	65	PG16	PG13,5	8	4	52,8
65-200/2.2	296	548	142	405	180	225	145	250	320	95	100	16	63	200	160	134	185	145	115	18	80	65	PG16	PG13,5	8	4	53
65-200/3.0	296	548	142	405	180	225	145	250	320	95	100	16	63	200	160	134	185	145	115	18	80	65	PG16	PG13,5	8	4	56,2

3LS4 80-160/1,5

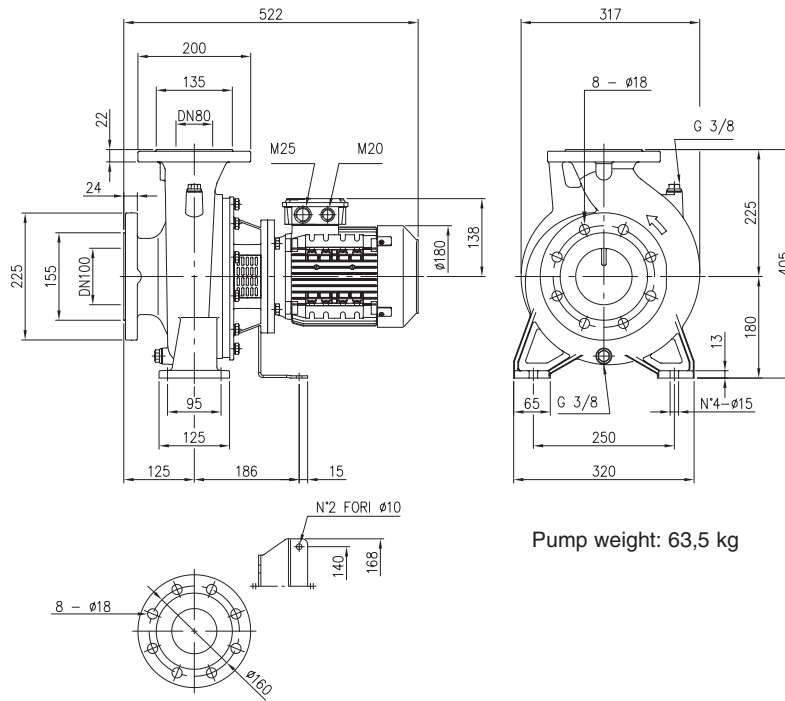

3S4 (3LS4) up to 80 size

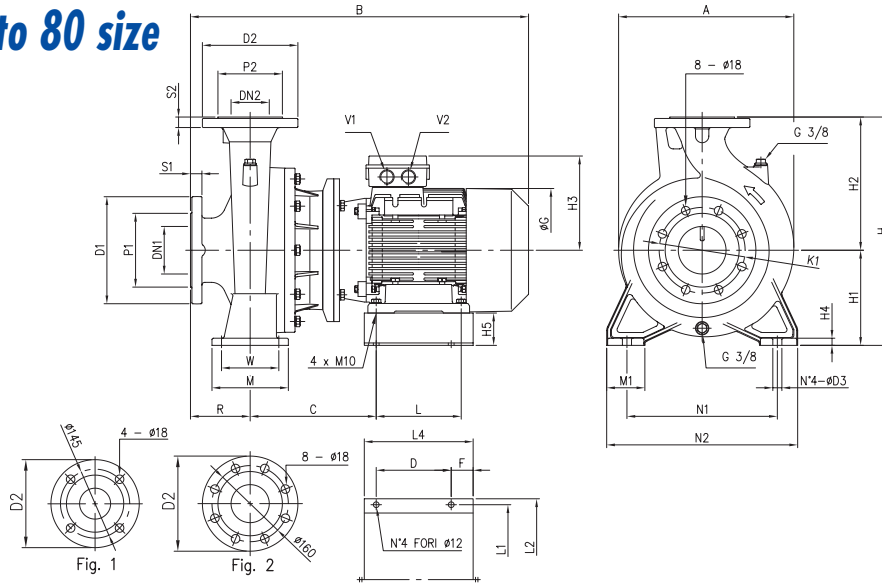

DIMENSIONAL TABLE

Pump type	Dimensions (mm)																							Weight (kg)												
	DN1	P1	K1	D1	S1	DN2	Fig.	P2	D2	S2	H	H1	H2	H3	H4	H5	R	W	N1	N2	M	M1	L		L1	L2	L4	A	B	C	D	F	G	D3	V1	V2
3LS4(.) 65-250/4	80	135	160	200	22	65	1	120	185	20	450	200	250	161	15	88	100	120	280	360	160	80	140	265	290	187	357	580	215	147	20	220	19	M25	M20	86
3LS4(.) 65-250/5.5	80	135	160	200	22	65	1	120	185	20	450	200	250	198	15	68	100	120	280	360	160	80	140	315	340	228	357	645	264	157	46	260	19	M32	M32	99,5
3LS4(.) 80-160/2.2R	100	155	180	225	24	80	2	135	200	22	405	180	225	145	13	80	125	95	250	320	125	65	140	250	275	190	317	573	205	140	25	196	15	M25	M20	69,5
3LS4(.) 80-200/2.2	100	155	180	225	24	80	2	135	200	22	405	180	225	145	13	80	125	95	250	320	125	65	140	250	275	190	317	573	205	140	25	196	15	M25	M20	70
3LS4(.) 80-200/3	100	155	180	225	24	80	2	135	200	22	430	180	250	145	13	80	125	95	280	345	125	65	140	250	275	190	354	583	215	140	25	196	15	M25	M20	81,5
3LS4(.) 80-200/4R	100	155	180	225	24	80	2	135	200	22	430	180	250	161	13	68	125	95	280	345	125	65	140	315	340	228	354	605	198	157	46	220	15	M24	M20	89,5
3LS4(.) 80-200/4	100	155	180	225	24	80	2	135	200	22	430	180	250	161	13	68	125	95	280	345	125	65	140	315	340	228	354	605	198	157	46	220	15	M25	M20	90
3LS4(.) 80-250/5.5R	100	155	180	225	24	80	2	135	200	22	480	200	280	198	15	68	125	120	315	400	160	80	140	315	340	228	367	670	264	157	46	260	19	M32	M32	104
3LS4(.) 80-250/5.5	100	155	180	225	24	80	2	135	200	22	480	200	280	198	15	68	125	120	315	400	160	80	140	315	340	228	367	670	264	157	46	260	19	M32	M32	104,5
3LS4(.) 80-250/7.5	100	155	180	225	24	80	2	135	200	22	480	200	280	198	15	68	125	120	315	400	160	80	178	315	340	228	367	708	264	157	46	260	19	M32	M32	109,5

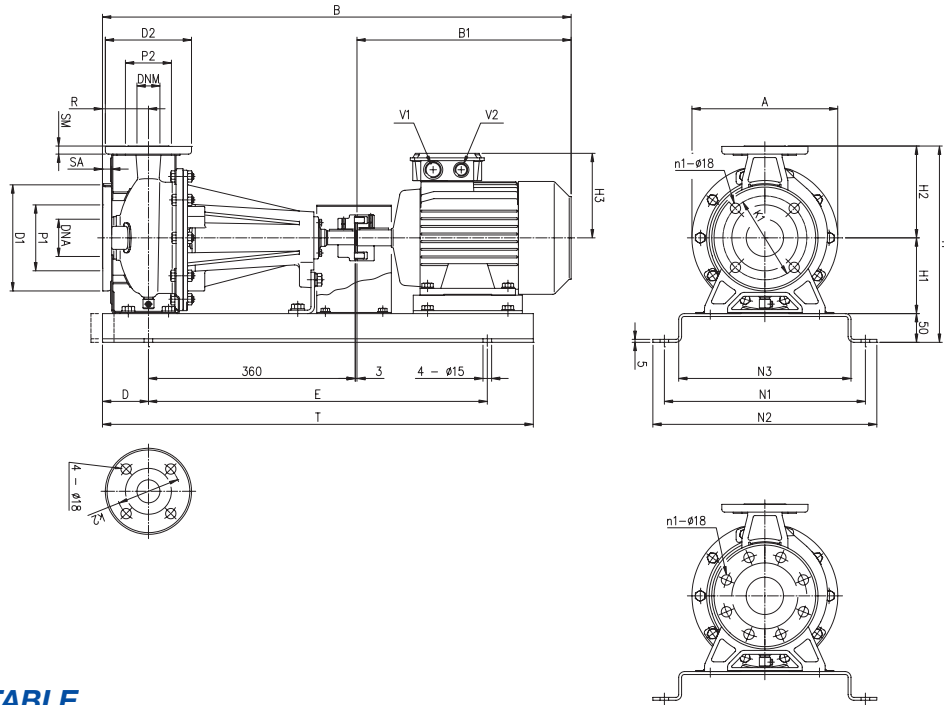

DIMENSIONAL TABLE

Pump type	Dimensions (mm)																												Weight (kg)	
	Ø DNA	Ø P1	n1 [1] [2]	Ø K1	Ø D1	SA	Ø DNM	Ø P2	Ø K2	Ø D2	SM	H	H1	H2	H3 [3] [4]	R	A	B	B1	D	E	N1	N2	N3	T	V1	V2			
3P 32-125/1.1 (M)	50	95	4	-	125	165	16	32	75	100	140	14	302	112	140	129	150	80	213	715	272	80	550	300	340	250	710	PG16	PG13,5	43,5
3P 32-160/1.5 (M)	50	95	4	-	125	165	16	32	75	100	140	14	342	132	160	138	160	80	254	760	317	80	590	350	390	300	750	PG16	PG13,5	51
3P 32-160/2.2 (M)	50	95	4	-	125	165	16	32	75	100	140	14	342	132	160	138	160	80	254	760	317	80	590	350	390	300	750	PG16	PG13,5	53,5
3P 32-200/3	50	95	4	-	125	165	16	32	75	100	140	14	390	160	180	145	-	80	296	809	366	80	590	350	390	300	750	PG16	PG13,5	68
3P 32-200/4	50	95	4	-	125	165	16	32	75	100	140	14	390	160	180	161	-	80	296	831	388	80	590	350	390	300	750	PG16	PG13,5	72
3P 32-200/5.5	50	95	4	-	125	165	16	32	75	100	140	14	390	160	180	198	-	80	296	893	450	100	650	350	390	300	850	PG21	PG21	88
3P 32-200/7.5	50	95	4	-	125	165	16	32	75	100	140	14	390	160	180	198	-	80	296	893	450	100	650	350	390	300	850	PG21	PG21	99,8
3P 40-125/1.5 (M)	65	115	4	-	145	185	16	40	80	110	150	14	302	112	140	138	160	80	213	760	317	80	550	300	340	250	710	PG16	PG13,5	48,5
3P 40-125/2.2 (M)	65	115	4	-	145	185	16	40	80	110	150	14	302	112	140	138	160	80	213	760	317	80	550	300	340	250	710	PG16	PG13,5	51
3P 40-160/3	65	115	4	-	145	185	16	40	80	110	150	14	342	132	160	145	-	80	254	809	366	80	590	350	390	300	750	PG16	PG13,5	77,5
3P 40-160/4	65	115	4	-	145	185	16	40	80	110	150	14	342	132	160	161	-	80	254	831	388	80	590	350	390	300	750	PG16	PG13,5	64,5
3P 40-200/5.5	65	115	4	-	145	185	16	40	80	110	150	14	390	160	180	198	-	100	296	913	450	100	650	350	390	300	850	PG21	PG21	89
3P 40-200/7.5	65	115	4	-	145	185	16	40	80	110	150	14	390	160	180	198	-	100	296	913	450	100	650	350	390	300	850	PG21	PG21	94,5
3P 40-200/11	65	115	4	-	145	185	16	40	80	110	150	14	390	160	180	246	-	100	296	1076	613	100	800	380	420	330	1000	PG29	PG29	117
3P 50-125/2.2 (M)	65	115	4	-	145	185	16	50	95	125	165	16	342	132	160	138	160	100	254	780	317	80	590	350	390	300	750	PG16	PG13,5	75
3P 50-125/3	65	115	4	-	145	185	16	50	95	125	165	16	342	132	160	145	-	100	254	829	366	80	590	350	390	300	750	PG16	PG13,5	79
3P 50-125/4	65	115	4	-	145	185	16	50	95	125	165	16	342	132	160	161	-	100	254	851	388	80	590	350	390	300	750	PG16	PG13,5	81,5
3P 50-160/5.5	65	115	4	-	145	185	16	50	95	125	165	16	390	160	180	198	-	100	296	913	450	100	650	350	390	300	850	PG21	PG21	89
3P 50-160/7.5	65	115	4	-	145	185	16	50	95	125	165	16	390	160	180	198	-	100	296	913	450	100	650	350	390	300	850	PG21	PG21	94,5
3P 50-200/9.2	65	115	4	-	145	185	16	50	95	125	165	16	410	160	200	198	-	100	296	951	488	100	650	350	390	300	850	PG21	PG21	100
3P 50-200/11	65	115	4	-	145	185	16	50	95	125	165	16	410	160	200	246	-	100	296	1076	613	100	800	380	420	330	1000	PG29	PG29	117,5
3P 50-200/15	65	115	4	-	145	185	16	50	95	125	165	16	410	160	200	246	-	100	296	1076	613	100	800	380	420	330	1000	PG29	PG29	125,4
3P 65-125/4	80	134	8	4	160	200	18	65	115	145	185	16	390	160	180	161	-	100	254	851	388	80	590	350	390	300	750	PG16	PG13,5	82
3P 65-125/5.5	80	134	8	4	160	200	18	65	115	145	185	16	390	160	180	198	-	100	254	913	450	100	650	350	390	300	850	PG21	PG21	90
3P 65-125/7.5	80	134	8	4	160	200	18	65	115	145	185	16	390	160	180	198	-	100	254	913	450	100	650	350	390	300	850	PG21	PG21	97
3P 65-160/7.5	80	134	8	4	160	200	18	65	115	145	185	16	410	160	200	198	-	100	296	913	450	100	650	350	390	300	850	PG21	PG21	103
3P 65-160/9.2	80	134	8	4	160	200	18	65	115	145	185	16	410	160	200	198	-	100	296	951	450	100	650	350	390	300	850	PG21	PG21	107
3P 65-160/11	80	134	8	4	160	200	18	65	115	145	185	16	410	160	200	246	-	100	296	1076	613	100	800	380	420	330	1000	PG29	PG29	114
3P 65-160/15	80	134	8	4	160	200	18	65	115	145	185	16	410	160	200	246	-	100	296	1076	613	100	800	380	420	330	1000	PG29	PG29	119
3P 65-200/15	80	134	8	4	160	200	18	65	115	145	185	16	455	180	225	246	-	100	296	1076	613	100	800	380	420	330	1000	PG29	PG29	127
3P 65-200/18.5	80	134	8	4	160	200	18	65	115	145	185	16	455	180	225	246	-	100	296	1120	657	100	800	380	420	330	1000	PG29	PG29	139
3P 65-200/22	80	134	8	4	160	200	18	65	115	145	185	16	455	180	225	266	-	100	296	1175	712	100	800	410	450	360	1000	PG29	PG29	182

[1] Standard
 [2] On request
 [3] Only for three phase
 [4] Only for single phase

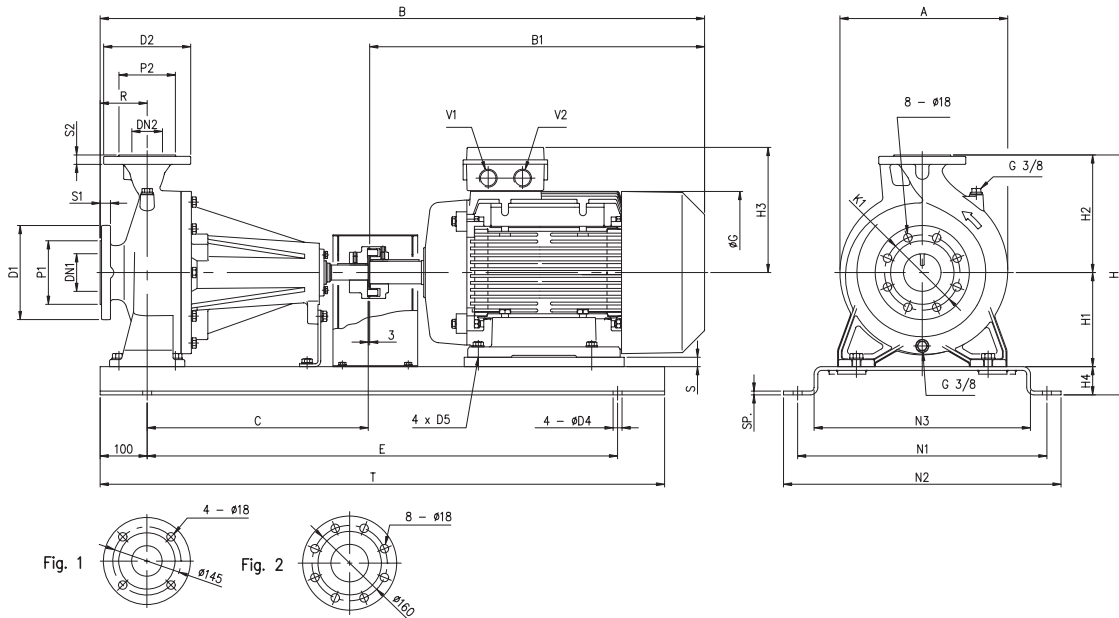

DIMENSIONAL TABLE

Pump type	Dimensions (mm)																												Weight (kg)			
	DN1	P1	D1	S1	DN2	Fig.	P2	D2	S2	H	H1	H2	H3	H4	R	N1	N2	N3	A	B	B1	C	G	E	T	S	D4	D5		Sp.	V1	V2
3LP(.) 65-250/30	80	135	200	22	65	1	120	185	20	510	200	250	341	60	100	530	590	460	357	1352	779	470	405	1000	1200	-	19	M16	8	M50	M50	354
3LP(.) 65-250/37	80	135	200	22	65	1	120	185	20	510	200	250	341	60	100	530	590	460	357	1352	779	470	405	1000	1200	-	19	M16	8	M50	M50	373
3LP(.) 80-160/11	100	155	225	24	80	2	135	200	22	455	180	225	246	50	125	380	420	330	317	1101	613	360	335	800	1000	20	15	M12	5	M40	M40	164
3LP(.) 80-160/15R	100	155	225	24	80	2	135	200	22	455	180	225	246	50	125	380	420	330	317	1101	613	360	335	800	1000	20	15	M12	5	M40	M40	176
3LP(.) 80-160/15	100	155	225	24	80	2	135	200	22	455	180	225	246	50	125	380	420	330	317	1101	613	360	335	800	1000	20	15	M12	5	M40	M40	176
3LP(.) 80-160/18.5	100	155	225	24	80	2	135	200	22	455	180	255	246	50	125	380	420	330	317	1145	657	360	335	800	1000	20	15	M12	5	M40	M40	185
3LP(.) 80-200/22	100	155	225	24	80	2	135	200	22	490	180	250	266	60	125	530	590	460	354	1310	712	470	366	1000	1200	-	19	M12	8	M40	M40	252
3LP(.) 80-250/37	100	155	225	24	80	2	135	200	22	540	200	280	341	60	125	530	590	460	367	1377	779	470	405	1000	1200	-	19	M16	8	M50	M50	377

3P (3LP)

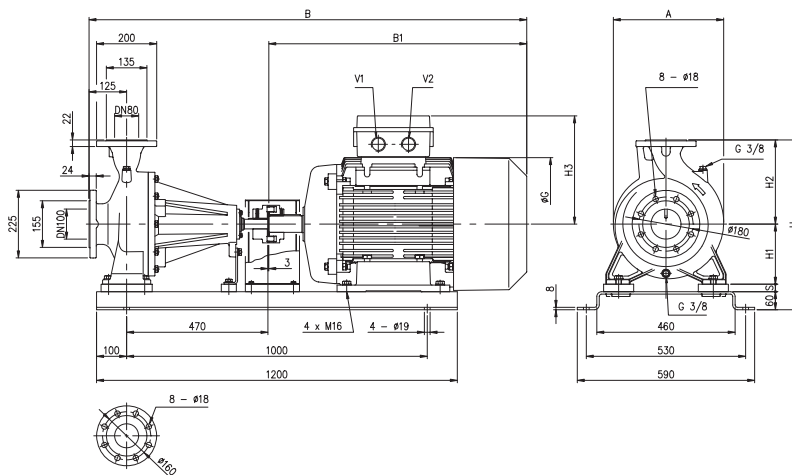

DIMENSIONAL TABLE

Pump type	Dimensions (mm)											Weight (kg)
	H	H1	H2	H3	A	B	B1	G	S	V1	V2	
3P 80-220/30	510	180	250	341	357	1377	779	405	20	M50	M50	356
3P 80-200/37	510	180	250	341	357	1377	779	405	20	M50	M50	365
3P 80-250/45	565	200	280	360	367	1456	858	463	25	M50	M50	440

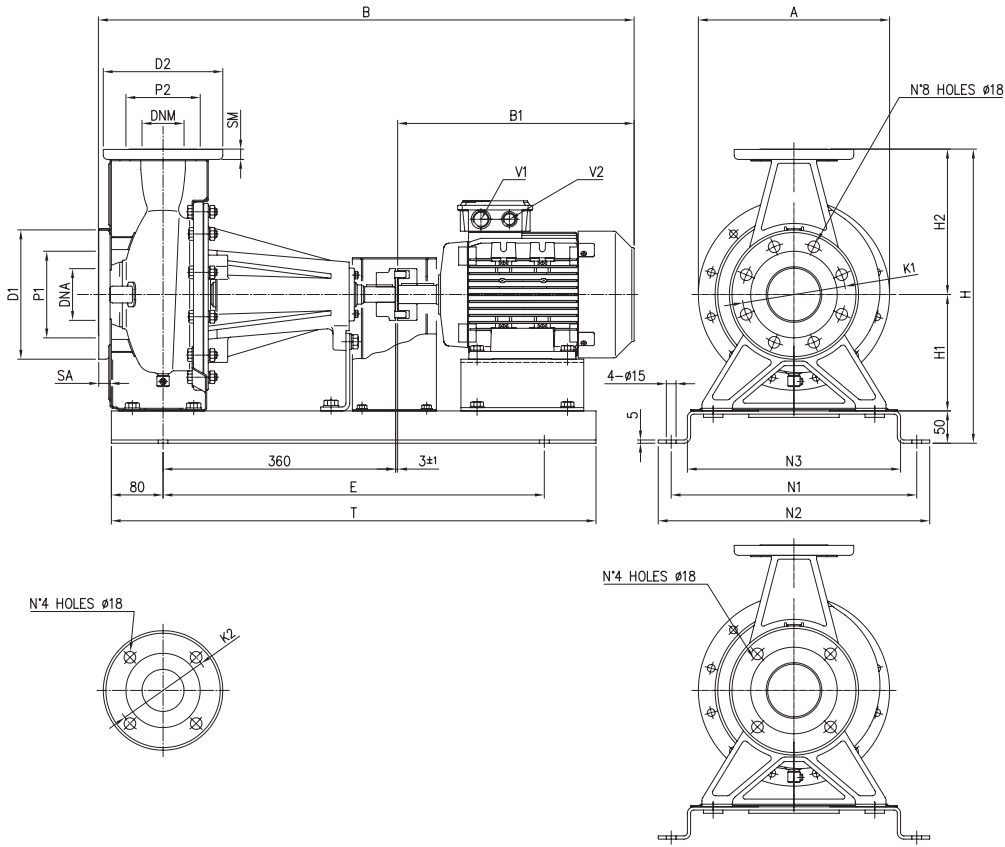

DIMENSIONAL TABLE

Pump type	Dimensions (mm)																	N. Holes		Weight (kg)						
	A	B	E	H	H1	H2	N1	N2	N3	B1	T	SA	SM	V1	V2	Ø D1	Ø K1	Ø P1	Ø D2		Ø K2	Ø P2	Ø DNA	Ø DNM	Standard	On request
32-125/0.25	213	683	550	302	112	140	300	340	250	240	710	16	14	PG11	PG13,5	165	125	95	140	100	75	50	32	4	-	37,0
32-160/0.37R	254	683	510	342	132	160	350	390	300	240	670	16	14	PG11	PG13,5	165	125	95	140	100	75	50	32	4	-	41,0
32-160/0.37	254	683	510	342	132	160	350	390	300	240	670	16	14	PG11	PG13,5	165	125	95	140	100	75	50	32	4	-	41,0
32-200/0.55R	296	717	510	390	160	180	350	390	300	274	670	16	14	PG13,5	PG16	165	125	95	140	100	75	50	32	4	-	53,5
32-200/0.55	296	717	510	390	160	180	350	390	300	274	670	16	14	PG13,5	PG16	165	125	95	140	100	75	50	32	4	-	53,5
32-200/0.75	296	717	510	390	160	180	350	390	300	274	670	16	14	PG13,5	PG16	165	125	95	140	100	75	50	32	4	-	54,5
40-125/0.37R	213	683	550	302	112	140	300	340	250	240	710	16	14	PG11	PG13,5	185	145	115	150	110	80	65	40	4	-	46,5
40-125/0.37	213	683	550	302	112	140	300	340	250	240	710	16	14	PG11	PG13,5	185	145	115	150	110	80	65	40	4	-	46,5
40-160/0.55R	254	717	510	342	132	160	350	390	300	274	670	16	14	PG13,5	PG16	185	145	115	150	110	80	65	40	4	-	44,5
40-160/0.55	254	717	510	342	132	160	350	390	300	274	670	16	14	PG13,5	PG16	185	145	115	150	110	80	65	40	4	-	44,5
40-200/1.1R	296	795	590	390	160	180	350	390	300	332	750	16	14	PG13,5	PG16	185	145	115	150	110	80	65	40	4	-	61,5
40-200/1.1	296	795	590	390	160	180	350	390	300	332	750	16	14	PG13,5	PG16	185	145	115	150	110	80	65	40	4	-	61,5
40-200/1.5	296	795	590	390	160	180	350	390	300	332	750	16	14	PG13,5	PG16	185	145	115	150	110	80	65	40	4	-	64,0
50-125/0.55R	254	737	510	342	132	160	350	390	300	274	670	16	16	PG13,5	PG16	185	145	115	165	125	95	65	50	4	-	45,0
50-125/0.55	254	737	510	342	132	160	350	390	300	274	670	16	16	PG13,5	PG16	185	145	115	165	125	95	65	50	4	-	45,0
50-160/1.1R	296	795	590	390	160	180	350	390	300	332	750	16	16	PG13,5	PG16	185	145	115	165	125	95	65	50	4	-	52,5
50-160/1.1	296	795	590	390	160	180	350	390	300	332	750	16	16	PG13,5	PG16	185	145	115	165	125	95	65	50	4	-	52,5
50-200/1.5R	296	795	590	410	160	200	350	390	300	332	750	16	16	PG13,5	PG16	185	145	115	165	125	95	65	50	4	-	64,0
50-200/1.5	296	795	590	410	160	200	350	390	300	332	750	16	16	PG13,5	PG16	185	145	115	165	125	95	65	50	4	-	64,0
50-200/2.2	296	863	590	410	160	200	350	390	300	400	750	16	16	PG13,5	PG16	185	145	115	165	125	95	65	50	4	-	70
65-125/0.55	254	735	510	390	160	180	350	390	300	272	670	18	16	PG16	PG13,5	200	160	134	185	145	115	80	80	8	4	48,6
65-125/0.75	254	735	510	390	160	180	350	390	300	272	670	18	16	PG16	PG13,5	200	160	134	185	145	115	80	80	8	4	49,8
65-125/1.1	254	780	590	390	160	180	350	390	300	317	750	18	16	PG16	PG13,5	200	160	134	185	145	115	80	80	8	4	56,1
65-160/1.1	296	780	590	410	160	200	350	390	300	317	750	18	16	PG16	PG13,5	200	160	134	185	145	115	80	80	8	4	62,6
65-160/1.5	296	780	590	410	160	200	350	390	300	317	750	18	16	PG16	PG13,5	200	160	134	185	145	115	80	80	8	4	63,7
65-160/2.2	296	829	590	410	160	200	350	390	300	366	750	18	16	PG16	PG13,5	200	160	134	185	145	115	80	80	8	4	71,5
65-200/2.2R	296	829	590	455	180	225	380	420	330	366	750	18	16	PG16	PG13,5	200	160	134	185	145	115	80	80	8	4	74,1
65-200/2.2	296	829	590	455	180	225	380	420	330	366	750	18	16	PG16	PG13,5	200	160	134	185	145	115	80	80	8	4	74,2
65-200/3.0	296	829	590	455	180	225	380	420	330	366	750	18	16	PG16	PG13,5	200	160	134	185	145	115	80	80	8	4	77,5

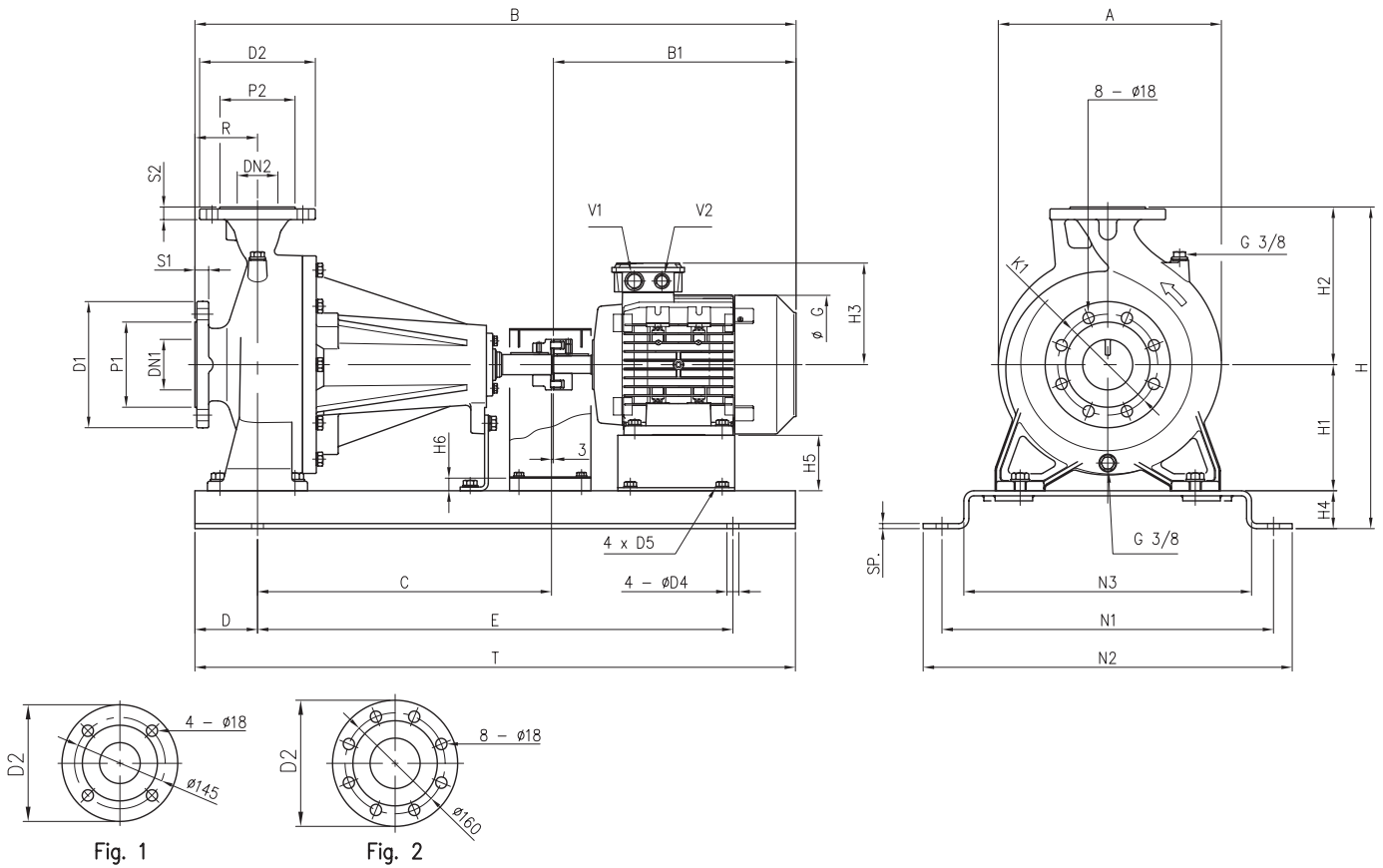

DIMENSIONAL TABLE

Pump type	Dimensions (mm)																										Weight (kg)							
	DN1	P1	D1	S1	DN2	Fig.	P2	D2	S2	H	H1	H2	H3	H4	H5	H6	R	N1	N2	N3	A	B	B1	C	D	G		E	T	D4	D5	Sp.	V1	V2
3LP4(.) 65-250/4	80	135	200	22	65	1	120	185	20	510	200	250	161	60	88	20	100	510	570	440	357	961	388	470	100	225	760	960	19	M10	8	M25	M20	113,5
3LP4(.) 65-250/5.5	80	135	200	22	65	1	120	185	20	510	200	250	198	60	68	-	100	510	570	440	357	1023	450	470	100	270	760	960	19	M10	8	M32	M32	130
3LP4(.) 80-160/1.5	100	155	225	24	80	2	135	200	22	455	180	225	138	50	90	20	125	380	420	330	317	805	317	360	80	180	590	750	15	M8	5	M25	M20	80
3LP4(.) 80-160/2.2R	100	155	225	24	80	2	135	200	22	455	180	225	145	50	80	-	125	380	420	330	317	854	366	360	80	196	590	750	15	M10	5	M25	M20	86
3LP4(.) 80-160/2.2	100	155	225	24	80	2	135	200	22	455	180	225	145	50	80	-	125	380	420	330	317	854	366	360	80	196	590	750	15	M10	5	M25	M20	100,5
3LP4(.) 80-200/3	100	155	225	24	80	2	135	200	22	490	180	250	145	60	80	-	125	460	520	390	354	964	366	470	100	196	700	900	19	M10	8	M25	M20	109,5
3LP4(.) 80-200/4R	100	155	225	24	80	2	135	200	22	490	180	250	161	60	68	-	125	460	520	390	354	986	388	470	100	225	700	900	19	M10	8	M25	M20	116,5
3LP4(.) 80-200/4	100	155	225	24	80	2	135	200	22	490	180	250	161	60	68	-	125	460	520	390	354	986	388	470	100	225	700	900	19	M10	8	M25	M20	117
3LP4(.) 80-250/5.5R	100	155	225	24	80	2	135	200	22	540	200	280	198	60	68	-	125	510	570	440	367	1048	450	470	100	270	760	960	19	M10	8	M32	M32	134
3LP4(.) 80-250/5.5	100	155	225	24	80	2	135	200	22	540	200	280	198	60	68	-	125	510	570	440	367	1048	450	470	100	270	760	960	19	M10	8	M32	M32	134,5
3LP4(.) 80-250/7.5	100	155	225	24	80	2	135	200	22	540	200	280	198	60	68	-	125	510	570	440	367	1086	488	470	100	270	760	960	19	M10	8	M32	M32	143,5

3SF (3LSF)

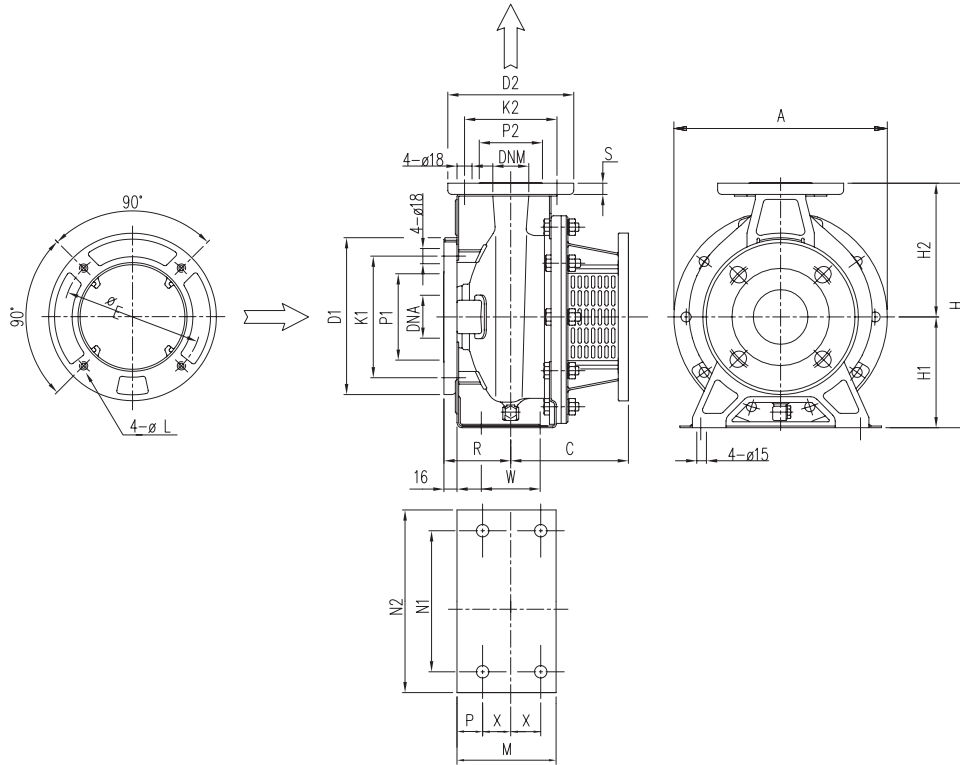

DIMENSIONAL TABLE

Pump type	Dimensions (mm)																						
	A	C	E	H	H1	H2	L	M	N1	N2	P	R	S	Ø D1	Ø K1	Ø P1	Ø D2	Ø K2	Ø P2	Ø DNA	Ø DNM	X	W
32-125/N	213	118	165	252	112	140	M10	114	140	190	29	80	14	165	125	96	140	100	76	50	32	35	70
32-160/R	254	130	165	292	132	160	M10	118	190	240	29	80	14	165	125	96	140	100	76	50	32	35	70
32-160/N	254	130	165	292	132	160	M10	118	190	240	29	80	14	165	125	96	140	100	76	50	32	35	70
32-200/R	294	142	215	340	160	180	M12	119	190	240	29	80	14	165	125	96	140	100	76	50	32	35	70
32-200/N	294	142	215	340	160	180	M12	119	190	240	29	80	14	165	125	96	140	100	76	50	32	35	70
32-200/L	294	165	265	340	160	180	M12	119	190	240	29	80	14	165	125	96	140	100	76	50	32	35	70
32-200/EL	294	165	265	340	112	180	M12	119	190	240	29	80	14	165	125	96	140	100	76	50	32	35	70
40-125/R	213	130	165	252	112	140	M10	114	160	210	29	80	14	185	145	116	150	110	81	65	40	35	70
40-125/N	213	130	165	252	132	140	M10	114	160	210	29	80	14	185	145	116	150	110	81	65	40	35	70
40-160/R	254	142	215	292	132	160	M12	118	190	240	29	80	14	185	145	116	150	110	81	65	40	35	70
40-160/N	254	142	215	292	160	160	M12	118	190	240	29	80	14	185	145	116	150	110	81	65	40	35	70
40-200/R	294	165	265	340	160	180	M12	115	212	265	25	80	14	185	145	116	150	110	81	65	40	35	70
40-200/N	294	165	265	340	160	180	M12	115	212	265	25	100	14	185	145	116	150	110	81	65	40	35	70
40-200/L	350	198	300	340	132	180	M16	115	212	265	25	100	14	185	145	116	150	110	81	65	40	35	70
50-125/S	254	142	215	292	132	160	M12	114	190	240	25	100	16	185	145	116	165	125	96	65	50	35	70
50-125/R	254	142	215	292	132	160	M12	114	190	240	25	100	16	185	145	116	165	125	96	65	50	35	70
50-125/N	254	142	215	292	160	160	M12	114	190	240	25	100	16	185	145	116	165	125	96	65	50	35	70
50-160/R	296	165	265	340	160	180	M12	115	212	265	25	100	16	185	145	116	165	125	96	65	50	35	70
50-160/N	296	165	265	340	160	180	M12	115	212	265	25	100	16	185	145	116	165	125	96	65	50	35	70
50-200/R	296	165	265	360	160	200	M12	115	212	265	25	390	16	185	145	116	165	125	96	65	50	35	7
50-200/N	350	198	300	360	160	200	M16	115	212	265	25	390	16	185	145	116	165	125	96	65	50	35	70
50-200/L	350	198	300	360	160	200	M16	115	212	265	25	390	16	185	145	116	165	125	96	65	50	35	70
65-125/R	254	142	215	340	160	180	M12	150	212	280	35	100	16	200	160	134	185	145	115	80	65	47,5	95
65-125/N	300	165	265	340	160	180	M12	150	212	280	35	100	16	200	160	134	185	145	115	80	65	47,5	95
65-125/L	300	165	265	340	160	180	M12	150	212	280	35	100	16	200	160	134	185	145	115	80	65	47,5	95
65-160/S	300	165	265	360	160	200	M12	150	212	280	35	100	16	200	160	134	185	145	115	80	65	47,5	95
65-160/R	300	165	265	360	160	200	M12	150	212	280	35	100	16	200	160	134	185	145	115	80	65	47,5	95
65-160/N	350	198	300	360	160	200	M16	150	212	280	35	100	16	200	160	134	185	145	115	80	65	47,5	95
65-160/L	350	208	300	360	160	200	M16	150	212	280	35	100	16	200	160	134	185	145	115	80	65	47,5	95
65-200/R	350	208	300	405	225	180	M16	150	212	320	35	100	16	200	160	134	185	145	115	80	65	47,5	95
65-200/N	350	208	300	405	225	180	M16	150	212	320	35	100	16	200	160	134	185	145	115	80	65	47,5	95
65-200/L	350	208	300	405	225	180	M16	150	212	320	35	100	16	200	160	134	185	145	115	80	65	47,5	95

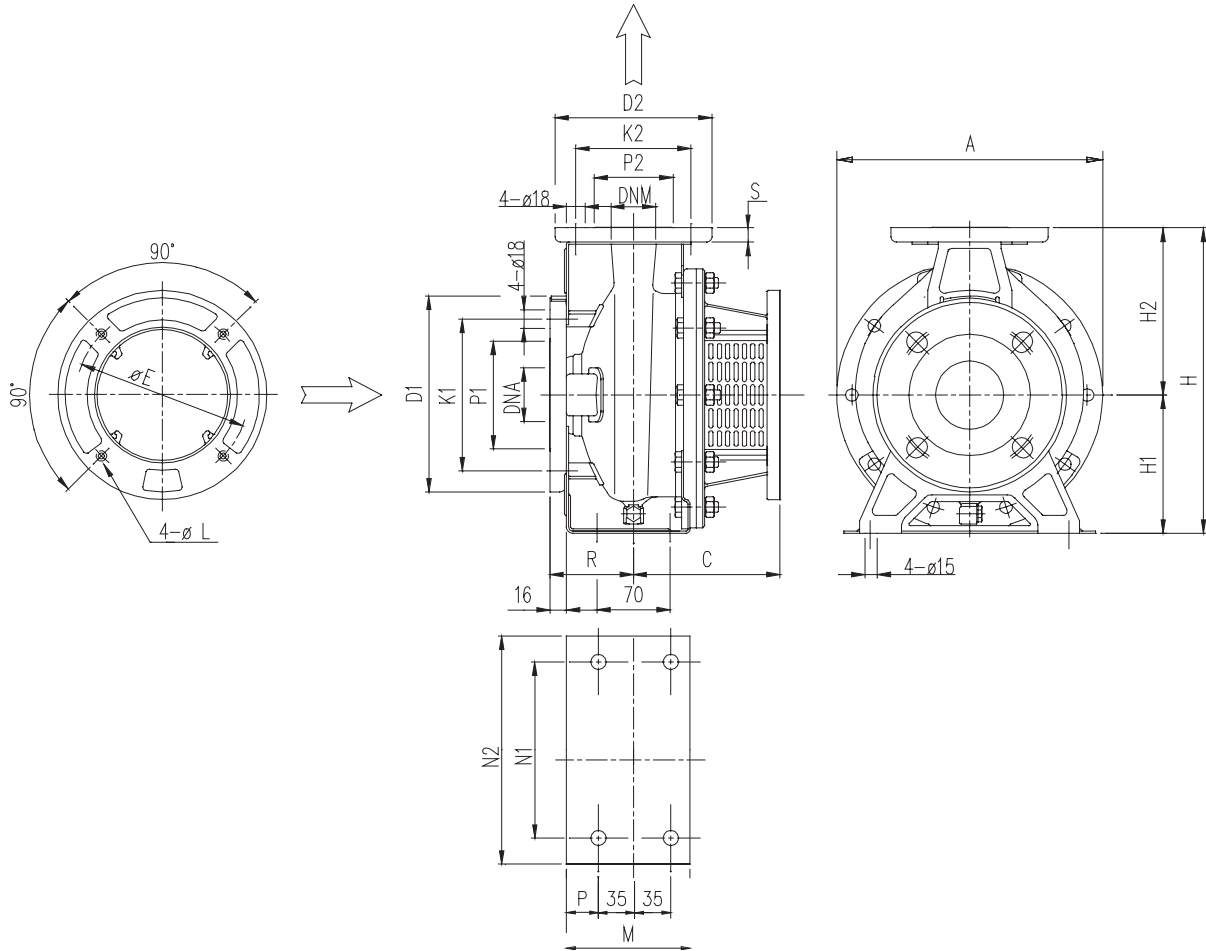

DIMENSIONAL TABLE

Pump type	Dimensions (mm)																				
	A	C	E	H	H1	H2	L	M	N1	N2	P	R	S	∅ D1	∅ K1	∅ P1	∅ D2	∅ K2	∅ P2	∅ DNA	∅ DNM
32-125/N	213	108	130	252	112	140	M8	114	140	190	29	80	14	165	125	96	140	100	76	50	32
32-160/R	254	108	130	292	132	160	M8	118	190	240	29	80	14	165	125	96	140	100	76	50	32
32-160/N	254	108	130	292	132	160	M8	118	190	240	29	80	14	165	125	96	140	100	76	50	32
32-200/R	296	118	165	340	160	180	M10	119	190	240	29	80	14	165	125	96	140	100	76	50	32
32-200/N	296	118	165	340	160	180	M10	119	190	240	29	80	14	165	125	96	140	100	76	50	32
32-200/L	296	118	165	340	160	180	M10	119	190	240	29	80	14	165	125	96	140	100	76	50	32
40-125/R	213	118	130	252	112	140	M8	114	160	210	29	80	14	185	145	116	150	110	81	65	40
40-125/N	213	118	130	252	112	140	M8	114	160	210	29	80	14	185	145	116	150	110	81	65	40
40-160/R	254	118	165	292	132	160	M10	118	190	240	29	80	14	185	145	116	150	110	81	65	40
40-160/N	254	118	165	292	132	160	M10	118	190	240	29	80	14	185	145	116	150	110	81	65	40
40-200/R	294	130	165	340	160	180	M10	115	212	265	25	100	14	185	145	116	150	110	81	65	40
40-200/N	294	130	165	340	160	180	M10	115	212	265	25	100	14	185	145	116	150	110	81	65	40
40-200/L	294	130	165	340	160	180	M10	115	212	265	25	100	14	185	145	116	150	110	81	65	40
50-125/R	254	118	165	292	132	160	M10	114	190	240	25	100	16	185	145	116	165	125	96	65	50
50-125/N	254	118	165	292	132	160	M10	114	190	240	25	100	16	185	145	116	165	125	96	65	50
50-160/R	296	130	165	340	160	180	M10	115	212	25	100	16	185	145	116	165	125	96	65	50	
50-160/N	296	130	165	340	160	180	M10	115	212	25	100	16	185	145	116	165	125	96	65	50	
50-200/R	296	130	165	360	160	200	M10	115	212	265	25	100	16	185	145	116	165	125	96	65	50
50-200/N	296	130	165	360	160	200	M10	115	212	265	25	100	16	185	145	116	165	125	96	65	50
50-200/L	296	130	215	360	160	200	M12	115	212	265	25	100	16	185	145	116	165	125	96	65	50

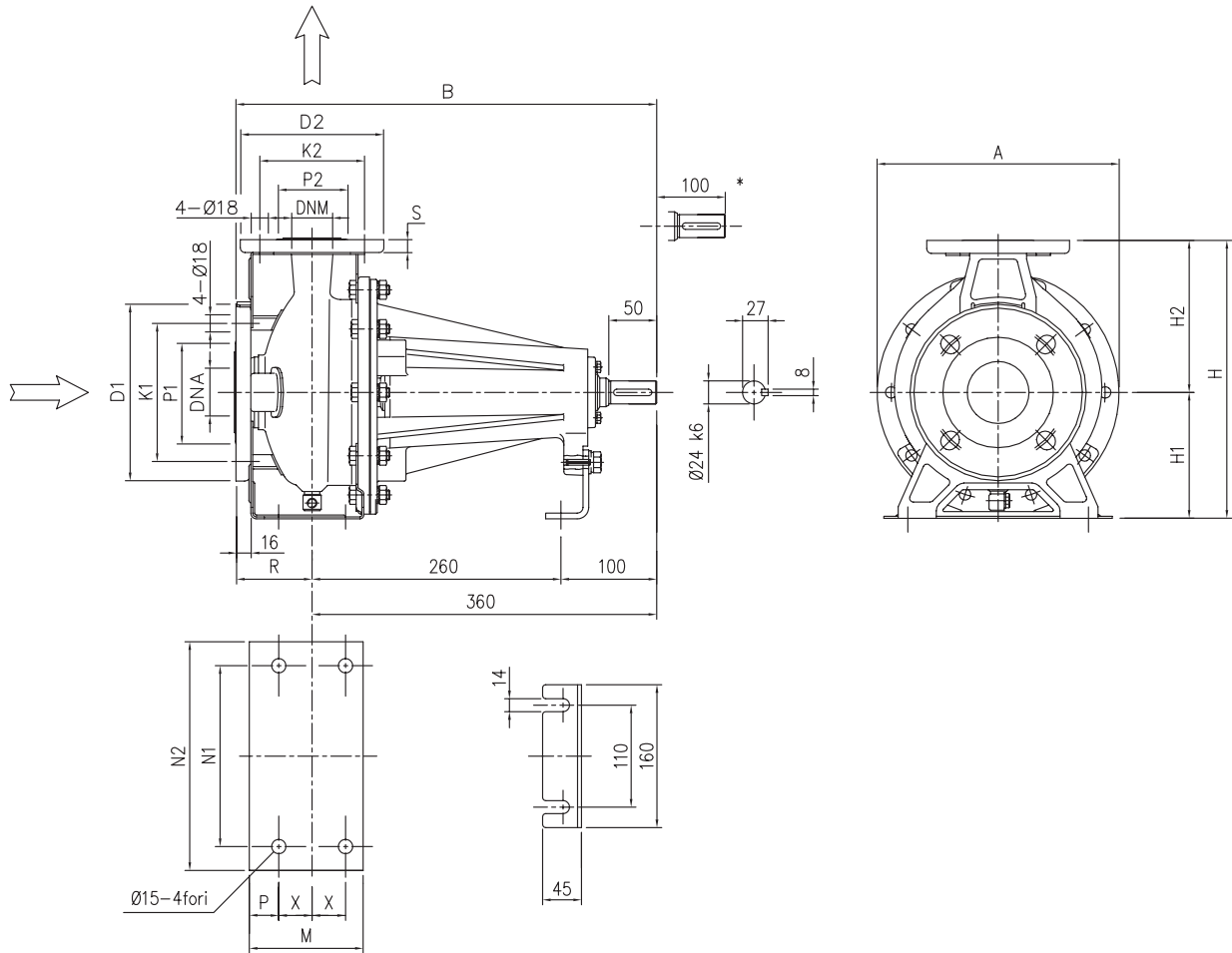

DIMENSIONAL TABLE

Pump type	Dimensions (mm)																			
	A	C	H	H1	H2	M	N1	N2	P	R	S	Ø D1	Ø K1	Ø P1	Ø D2	Ø K2	Ø P2	Ø DNA	Ø DNM	X
32-125	213	440	252	112	140	114	140	190	29	80	14	165	125	95	140	100	75	50	32	35
32-160	254	440	292	132	160	118	190	240	29	80	14	165	125	95	140	100	75	50	32	35
32-200	296	440	340	160	180	119	190	240	29	80	14	165	125	95	140	100	75	50	32	35
40-125	213	440	252	112	140	114	160	210	29	80	14	185	145	115	150	110	80	65	40	35
40-160	254	440	292	132	160	118	190	240	29	80	14	185	145	115	150	110	80	65	40	35
40-200	296	460	340	160	180	115	212	265	25	100	14	185	145	115	150	110	80	65	40	35
50-125	254	460	292	132	160	114	190	240	25	100	14	185	145	115	165	125	95	65	50	35
50-160	296	460	340	160	180	115	212	265	25	100	16	185	145	115	165	125	95	65	50	35
50-200	296	460	360	160	200	115	212	265	25	100	16	185	145	115	165	125	95	65	50	35
65-125	254	460	340	160	180	150	212	280	35	100	16	200	160	134	185	145	115	80	65	47,5
65-160	296	460	360	160	200	150	212	280	35	100	16	200	160	134	185	145	115	80	65	47,5
65-200	296	460	405	180	225	150	212	280	35	100	16	200	160	134	185	145	115	80	65	47,5

* Space where it is possible to disassemble the pump with coupling spacer without disassembling the motor.

3-3L SERIES

CENTRIFUGAL PUMPS according EN 733 (ex DIN 24255) STANDARD
4 POLES

3(L)PF4

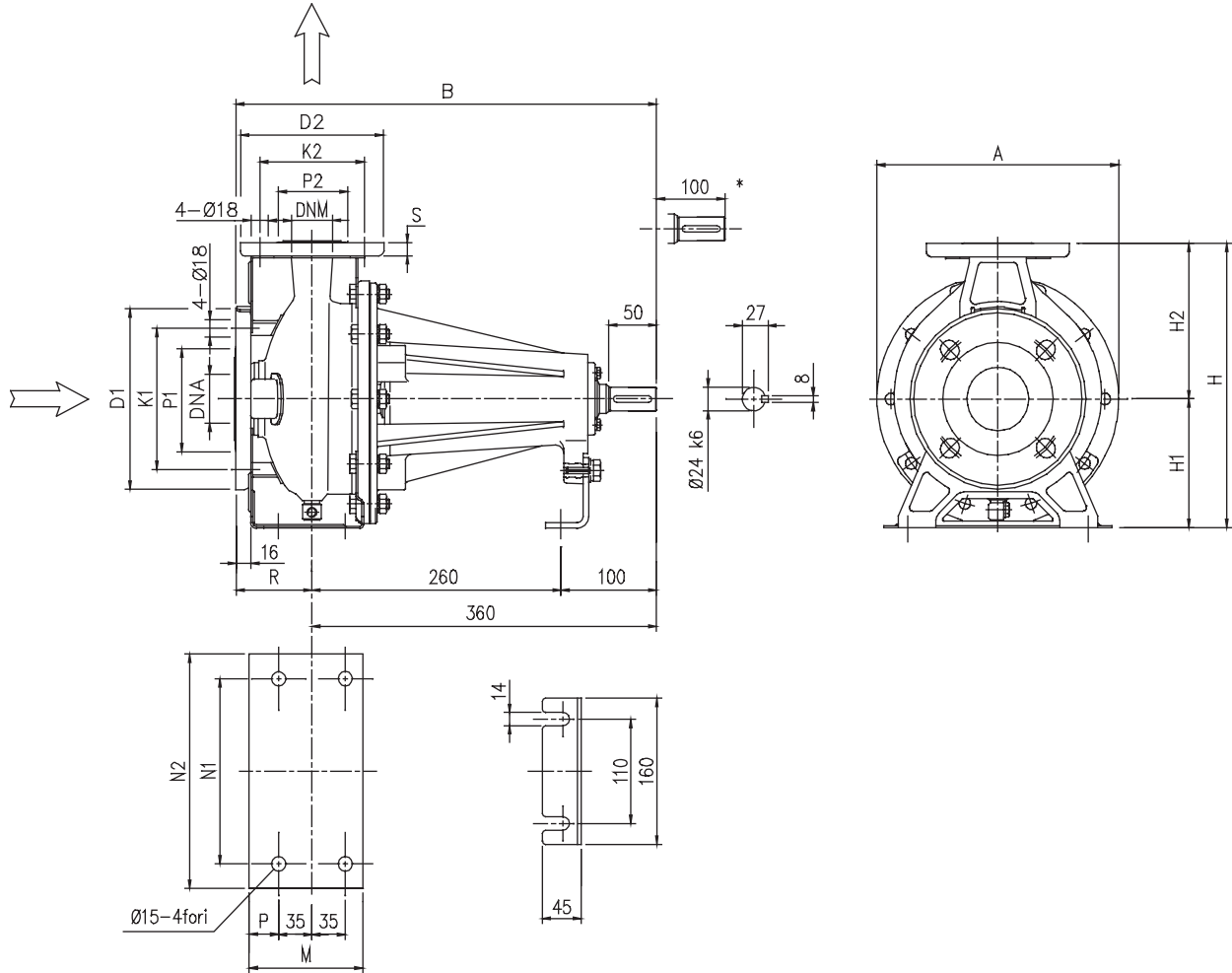

DIMENSIONAL TABLE

Pump type	Dimensions (mm)																		
	A	B	H	H1	H2	M	N1	N2	P	R	S	Ø D1	Ø K1	Ø P1	Ø D2	Ø K2	Ø P2	Ø DNA	Ø DNM
32-125	213	440	252	112	140	114	140	190	29	80	14	165	125	95	140	100	75	50	32
32-160	254	440	292	132	160	118	190	240	29	80	14	165	125	95	140	100	75	50	32
32-200	296	440	340	160	180	119	190	240	29	80	14	165	125	95	140	100	75	50	32
40-125	213	440	252	112	140	114	160	210	29	80	14	185	145	115	150	110	80	65	40
40-160	254	440	292	132	160	118	190	240	29	80	14	185	145	115	150	110	80	65	40
40-200	296	460	340	160	180	115	212	265	25	100	14	185	145	115	150	110	80	65	40
50-125	254	460	292	132	160	114	190	240	25	100	16	185	145	115	165	125	95	65	50
50-160	296	460	340	160	180	115	212	265	25	100	16	185	145	115	165	125	95	65	50
50-200	296	460	360	160	200	115	212	265	25	100	16	185	145	115	165	125	95	65	50

* Space where it is possible to disassemble the pump with coupling spacer without disassembling the motor.

3S (3LS) Series coupling

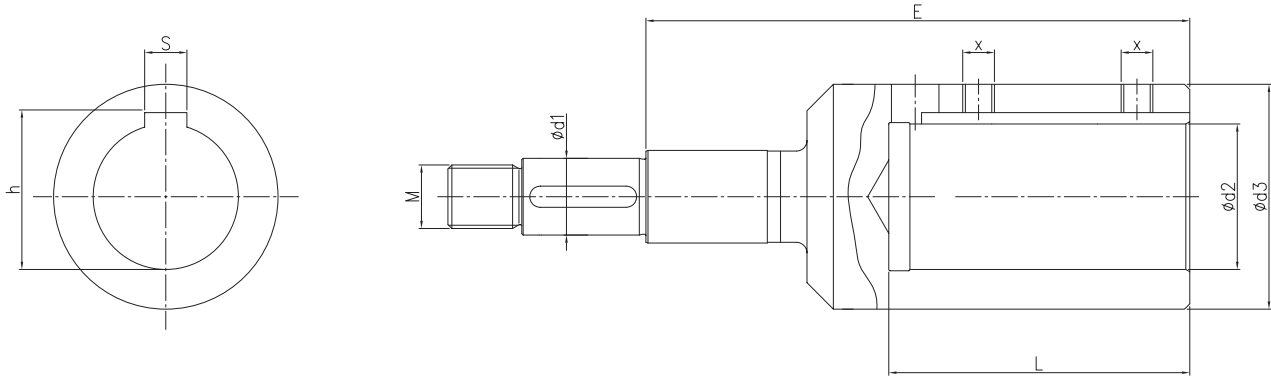

DIMENSIONAL TABLE up to 65 size

Pump type	kW	HP	Motor		Dimensions (mm)										
			Size	Type	d1	d2	d3	L3	M	Size	Standard	h	S	E	
32-125/1.1	1,1	1,5	80	B5	19	19	33	43	16 x 1,5	M 6 x 6	UNI 5929	21,8	6	98	
32-160/1.5	1,5	2	90	B5	19	24	39	53	16 x 1,5	M 8 x 8	UNI 5929	27,3	8	110	
32-160/2.2	2,2	3	90	B5	19	24	39	53	16 x 1,5	M 8 x 8	UNI 5929	27,3	8	110	
32-200/3.0	3	4	100	B35	19	28	43	63	16 x 1,5	M 8 x 8	UNI 5929	31,3	8	122	
32-200/4.0	4	5,5	112	B35	19	28	43	63	16 x 1,5	M 8 x 8	UNI 5929	31,3	8	122	
32-200/5.5	5,5	7,5	132	B35	19	38	58	84	16 x 1,5	M 8 x 8	UNI 5929	41,3	10	145	
32-200/7.5	7,5	10	132	B35	19	38	58	84	16 x 1,5	M 8 x 8	UNI 5929	41,3	10	145	
40-125/1.5	1,5	2	90	B5	19	24	39	53	16 x 1,5	M 8 x 8	UNI 5929	27,3	8	110	
40-125/2.2	2,2	3	90	B5	19	24	39	53	16 x 1,5	M 8 x 8	UNI 5929	27,3	8	110	
40-160/3.0	3	4	100	B35	19	28	43	63	16 x 1,5	M 8 x 8	UNI 5929	31,3	8	122	
40-160/4.0	4	5,5	112	B35	19	28	43	63	16 x 1,5	M 8 x 8	UNI 5929	31,3	8	122	
40-200/5.5	5,5	7,5	132	B35	19	38	58	84	16 x 1,5	M 8 x 8	UNI 5929	41,3	10	145	
40-200/7.5	7,5	10	132	B35	19	38	58	84	16 x 1,5	M 8 x 8	UNI 5929	41,3	10	145	
40-200/11	11	15	160	B35	19	42	63	114	16 x 1,5	M 8 x 8	UNI 5929	45,3	12	178	
50-125/2.2	2,2	3	90	B5	19	24	39	53	16 x 1,5	M 8 x 8	UNI 5929	27,3	8	110	
50-125/3.0	3	4	100	B35	19	28	43	63	16 x 1,5	M 8 x 8	UNI 5929	31,3	8	122	
50-125/4.0	4	5,5	112	B35	19	28	43	63	16 x 1,5	M 8 x 8	UNI 5929	31,3	8	122	
50-160/5.5	5,5	7,5	132	B35	19	38	58	84	16 x 1,5	M 8 x 8	UNI 5929	41,3	10	145	
50-160/7.5	7,5	10	132	B35	19	38	58	84	16 x 1,5	M 8 x 8	UNI 5929	41,3	10	145	
50-200/9.2	9,2	12,5	132	B35	19	38	58	84	16 x 1,5	M 8 x 8	UNI 5929	41,3	10	145	
50-200/11	11	15	160	B35	19	42	63	114	16 x 1,5	M 8 x 8	UNI 5929	45,3	12	178	
50-200/15	15	20	160	B35	22	42	63	114	18 x 1,5	M 8 x 8	UNI 5929	45,3	12	209	
65-125/4.0	4	5,5	112	B35	19	28	43	63	16 x 1,5	M 8 x 8	UNI 5929	31,3	8	122	
65-125/5.5	5,5	7,5	132	B35	19	38	58	84	16 x 1,5	M 8 x 8	UNI 5929	41,3	10	145	
65-125/7.5	7,5	10	132	B35	19	38	58	84	16 x 1,5	M 8 x 8	UNI 5929	41,3	10	145	
65-160/7.5	7,5	10	132	B35	19	38	58	84	16 x 1,5	M 8 x 8	UNI 5929	41,3	10	145	
65-160/9.2	9,2	12,5	132	B35	19	38	58	84	16 x 1,5	M 8 x 8	UNI 5929	41,3	10	145	
65-160/11	11	15	160	B35	19	42	63	114	16 x 1,5	M 8 x 8	UNI 5929	45,3	12	178	
65-160/15	15	20	160	B35	24	42	63	114	20 x 1,5	M 8 x 8	UNI 5929	45,3	12	184	
65-200/15	15	20	160	B35	24	42	63	114	20 x 1,5	M 8 x 8	UNI 5929	45,3	12	184	
65-200/18.5	18,5	25	160	B35	24	42	63	114	20 x 1,5	M 8 x 8	UNI 5929	45,3	12	184	
65-200/22	22	30	180	B35	24	48	72	114	20 x 1,5	M 10 x 10	UNI 5929	51,8	14	184	

DIMENSIONAL TABLE up to 80 size

Pump type	kW	HP	Motor		Dimensions (mm)										
			Size	Type	d1	d2	d3	L	M	Size	Standard	h	S	E	
65-250/30	30	40	200	B35	24	55	85	114	20 x 1,5	M 12 x 12	UNI 5923	59,3	16	184	
65-250/37	37	50	200	B35	24	55	85	114	20 x 1,5	M 12 x 12	UNI 5923	59,3	16	184	
80-160/11	11	15	160	B35	24	42	63	114	20 x 1,5	M 8 x 8	UNI 5929	45,3	12	184	
80-160/15R	15	20	160	B35	24	42	63	114	20 x 1,5	M 8 x 8	UNI 5929	45,3	12	184	
80-160/15	15	20	160	B35	24	42	63	114	20 x 1,5	M 8 x 8	UNI 5929	45,3	12	184	
80-160/18.5	18,5	25	160	B35	24	42	63	144	20 x 1,5	M 8 x 8	UNI 5929	45,3	12	184	
80-200/22	22	30	180	B35	24	48	72	114	20 x 1,5	M 10 x 10	UNI 5929	51,8	14	184	
80-200/30	30	40	200	B35	24	55	85	114	20 x 1,5	M 12 x 12	UNI 5923	59,3	16	184	
80-200/37	37	50	200	B35	24	55	85	114	20 x 1,5	M 12 x 12	UNI 5923	59,3	16	184	
80-250/37	37	50	200	B35	29	55	85	114	24 x 2	M 12 x 12	UNI 5923	59,3	16	206	
80-250/45	45	60	225	B35	29	55	85	114	24 x 2	M 12 x 12	UNI 5923	59,3	16	206	
80-250/55	55	75	250	B35	29	60	89	144	24 x 2	M 12 x 12	UNI 5923	64,4	18	218	

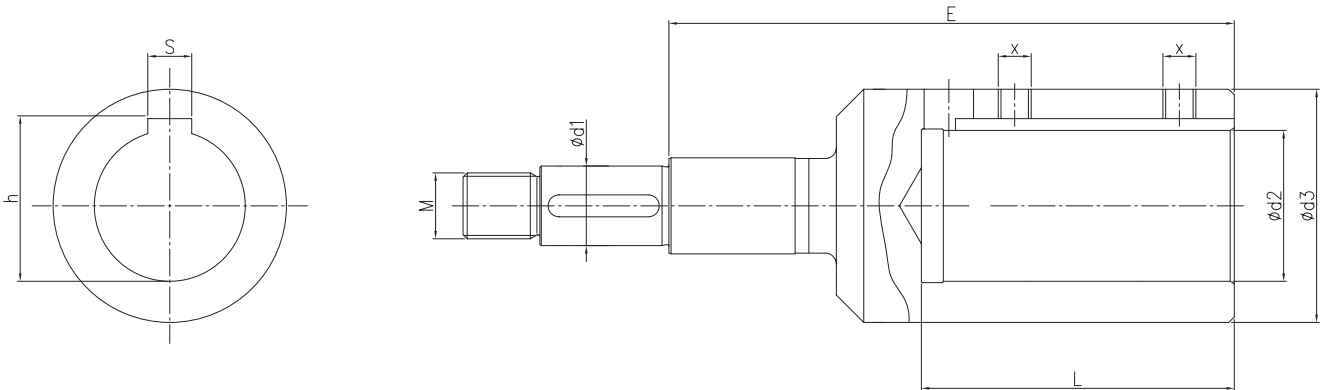

DIMENSIONAL TABLE up to 65 size

Pump type	kW	HP	Motor		Dimensions (mm)									
			HA	Type	D	d	L3	M	X	h	S	E	A	
32-125/0.25	0,25	0,33	71	B5	28	14	33	M 16 x 1,5	M 5 x 6	16,3	5	88	19	
32-160/0.37R	0,37	0,5	71	B5	28	14	33	M 16 x 1,5	M 5 x 6	16,3	5	88	19	
32-160/0.37	0,37	0,5	71	B5	28	14	33	M 16 x 1,5	M 5 x 6	16,3	5	88	19	
32-200/0.55R	0,55	0,75	80	B5	33	19	43	M 16 x 1,5	M 6 x 6	21,8	6	98	19	
32-200/0.55	0,55	0,75	80	B5	33	19	43	M 16 x 1,5	M 6 x 6	21,8	6	98	19	
32-200/0.75	0,75	1	80	B5	33	19	43	M 16 x 1,5	M 6 x 6	21,8	6	98	19	
40-125/0.37R	0,37	0,5	71	B5	28	14	33	M 16 x 1,5	M 5 x 6	16,3	5	88	19	
40-125/0.37	0,37	0,5	71	B5	28	14	33	M 16 x 1,5	M 5 x 6	16,3	5	88	19	
40-160/0.55R	0,55	0,75	80	B5	33	19	43	M 16 x 1,5	M 6 x 6	21,8	6	98	19	
40-160/0.55	0,55	0,75	80	B5	33	19	43	M 16 x 1,5	M 6 x 6	21,8	6	98	19	
40-200/1.1R	1,1	1,5	90	B5	39	24	53	M 16 x 1,5	M 8 x 8	27,3	8	110	19	
40-200/1.1	1,1	1,5	90	B5	39	24	53	M 16 x 1,5	M 8 x 8	27,3	8	110	19	
40-200/1.5	1,5	2	90	B5	39	24	53	M 16 x 1,5	M 8 x 8	27,3	8	110	19	
50-125/0.55R	0,55	0,75	80	B5	33	19	43	M 16 x 1,5	M 6 x 6	21,8	6	98	19	
50-125/0.55	0,55	0,75	80	B5	33	19	43	M 16 x 1,5	M 6 x 6	21,8	6	98	19	
50-160/1.1R	1,1	1,5	90	B5	39	24	53	M 16 x 1,5	M 8 x 8	27,3	8	110	19	
50-160/1.1	1,1	1,5	90	B5	39	24	53	M 16 x 1,5	M 8 x 8	27,3	8	110	19	
50-200/1.5R	1,5	2	90	B5	39	24	53	M 16 x 1,5	M 8 x 8	27,3	8	110	19	
50-200/1.5	1,5	2	90	B5	39	24	53	M 16 x 1,5	M 8 x 8	27,3	8	110	19	
50-200/2.2	2,2	3	100	B35	43	28	63	M 18 x 1,5	M 8 x 8	31,3	8	153	22	
65-125/0.55	0,55	0,75	80	B5	33	19	43	M 16 x 1,5	M 6 x 6	21,8	6	98	19	
65-125/0.75	0,75	1	80	B5	33	19	43	M 18 x 1,5	M 6 x 6	21,8	6	98	19	
65-125/1.1	1,1	1,5	90	B5	39	24	53	M 16 x 1,5	M 8 x 8	27,3	8	110	19	
65-160/1.1	1,1	1,5	90	B5	39	24	53	M 16 x 1,5	M 8 x 8	27,3	8	110	19	
65-160/1.5	1,5	2	90	B5	39	24	53	M 16 x 1,5	M 8 x 8	27,3	8	110	19	
65-160/2.2	2,2	3	100	B35	43	28	63	M 16 x 1,5	M 8 x 8	31,3	8	122	19	
62-200/2.2R	2,2	3	100	B35	43	28	63	M 16 x 1,5	M 8 x 8	31,3	8	122	19	
65-200/2.2	2,2	3	100	B35	43	28	63	M 16 x 1,5	M 8 x 8	31,3	8	122	19	
65-200/3.0	3	4	100	B35	43	28	63	M 16 x 1,5	M 8 x 8	31,3	8	122	19	

DIMENSIONAL TABLE up to 80 size

Pump type	kW	HP	Motor		Dimensions (mm)									
			Size	Type	d1	d2	d3	L	M	X	h	S	E	
65-250/4	4	5,5	112	B35	24	28	45	63	20 x 1,5	M 8 x 8	UNI 5929	31,3	8	128
65-250/5.5	5,5	7,5	132	B35	24	38	58	84	20 x 1,5	M 8 x 8	UNI 5929	41,3	10	151
80-160/1.5	1,5	2	90	B5	19	24	39	53	16 x 1,5	M 8 x 8	UNI 5929	27,3	8	110
80-160/2.2R	2,2	3	100	B35	19	28	43	63	16 x 1,5	M 8 x 8	UNI 5929	31,3	8	122
80-160/2.2	2,2	3	100	B35	19	28	43	63	16 x 1,5	M 8 x 8	UNI 5929	31,3	8	122
80-200/3	3	4	100	B35	24	28	54	63	20 x 1,5	M 8 x 8	UNI 5929	31,3	8	128
80-200/4R	4	5,5	112	B35	24	28	54	63	20 x 1,5	M 8 x 8	UNI 5929	31,3	8	128
80-200/4	4	5,5	112	B35	24	28	54	63	20 x 1,5	M 8 x 8	UNI 5929	31,3	8	128
80-250/5.5R	5,5	7,5	132	B35	24	38	58	84	20 x 1,5	M 8 x 8	UNI 5929	41,3	10	151
80-250/5.5	5,5	7,5	132	B35	24	38	58	84	20 x 1,5	M 8 x 8	UNI 5929	41,3	10	151
80-250/7.5	7,5	10	132	B35	24	38	58	84	20 x 1,5	M 8 x 8	UNI 5929	41,3	10	151

3(L)P - 3(L)P4 Series coupling

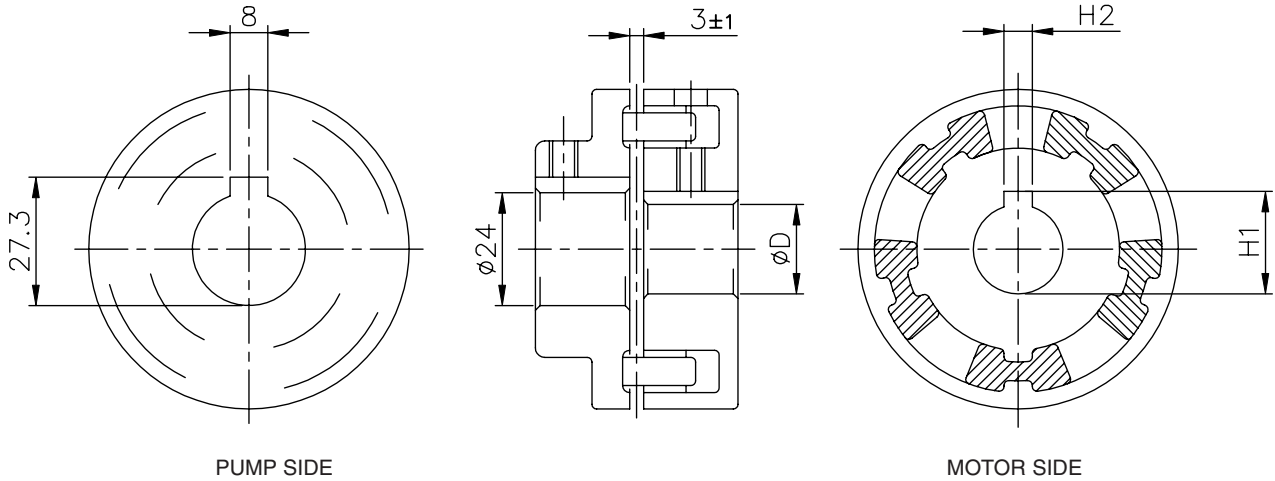

DIMENSIONAL TABLES

2 POLES

Pump type 3(L)P	kW	HP	Motor		Dimensions (mm)		
			Size	Type	D	H1	H2
32-125/1,1	1,1	1,5	80	B3	19	21,8	6
32-160/1,5	1,5	2	90	B3	24	27,3	8
32-160/2,2	2,2	3	90	B3	24	27,3	8
32-200/3,0	3	4	100	B3	28	31,3	8
32-200/4,0	4	5,5	112	B3	28	31,3	8
32-200/5,5	5,5	7,5	132	B3	38	41,3	10
32-200/7,5	7,5	10	132	B3	38	41,3	10
40-125/1,5	1,5	2	90	B3	24	27,3	8
40-125/2,2	2,2	3	90	B3	24	27,3	8
40-160/3,0	3	4	100	B3	28	31,3	8
40-160/4,0	4	5,5	112	B3	28	31,3	8
40-200/5,5	5,5	7,5	132	B3	38	41,3	10
40-200/7,5	7,5	10	132	B3	38	41,3	10
40-200/11	11	15	160	B3	42	45,3	12
50-125/2,2	2,2	3	90	B3	24	27,3	8
50-125/3,0	3	4	100	B3	28	31,3	8
50-125/4,0	4	5,5	112	B3	28	31,3	8
50-160/5,5	5,5	7,5	132	B3	38	41,3	10
50-160/7,5	7,5	10	132	B3	38	41,3	10
50-200/9,2	9,2	12,5	132	B3	38	41,3	10
50-200/11	11	15	160	B3	42	45,3	12
50-200/15	15	20	160	B3	42	45,3	12
65-125/4,0	4	5,5	112	B3	28	31,3	8
65-125/5,5	5,5	7,5	132	B3	38	41,3	10
65-125/7,5	7,5	10	132	B3	38	41,3	10
65-160/7,5	7,5	10	132	B3	38	41,3	10
65-160/9,2	9,2	12,5	132	B3	38	41,3	10
65-160/11	11	15	160	B3	42	45,3	12
65-160/15	15	20	160	B3	42	45,3	12
65-200/15	15	20	160	B3	42	45,3	12
65-200/18,5	18,5	25	160	B3	42	45,3	12
65-200/22	22	30	180	B3	48	51,8	14

4 POLES

Pump type 3(L)P4	kW	HP	Motor		Dimensions (mm)		
			Size	Type	D	H1	H2
32-125/0,25	0,25	0,33	71	B3	14	16,3	5
32-160/0,37R	0,37	0,5	71	B3	14	16,3	5
32-160/0,37	0,37	0,5	71	B3	14	16,3	5
32-200/0,55R	0,55	0,75	80	B3	19	21,8	6
32-200/0,55	0,55	0,75	80	B3	19	21,8	6
32-200/0,75	0,75	1	80	B3	19	21,8	6
40-125/0,37R	0,37	0,5	71	B3	14	16,3	5
40-125/0,37	0,37	0,5	71	B3	14	16,3	5
40-160/0,55R	0,55	0,75	80	B3	19	21,3	6
40-160/0,55	0,55	0,75	80	B3	19	21,3	6
40-200/1,1R	1,1	1,5	90	B3	24	27,3	8
40-200/1,1	1,1	1,5	90	B3	24	27,3	8
40-200/1,5	1,5	2	90	B3	24	27,3	8
50-125/0,55R	0,55	0,75	80	B3	19	21,3	6
50-125/0,55	0,55	0,75	80	B3	19	21,3	6
50-160/1,1R	1,1	1,5	90	B3	24	27,3	8
50-160/1,1	1,1	1,5	90	B3	24	27,3	8
50-200/1,5R	1,5	2	90	B3	24	27,3	8
50-200/1,5	1,5	2	90	B3	24	27,3	8
50-200/2,2	2,2	3	100	B3	28	31,3	8
65-125/0,55	0,55	0,75	80	B3	19	21,8	6
65-125/0,75	0,75	1	80	B3	19	21,8	6
65-125/1,1	1,1	1,5	90	B3	24	27,3	8
65-160/1,1	1,1	1,5	90	B3	24	27,3	8
65-160/1,5	1,5	2	90	B3	24	27,3	8
65-160/2,2	2,2	3	100	B3	28	31,3	8
65-200/2,2R	2,2	3	100	B3	28	31,3	8
65-200/2,2	2,2	3	100	B3	28	31,3	8
65-200/3,0	3	4	100	B3	28	31,3	8

3S (3LS) - 3S (L) P4 Series coupling

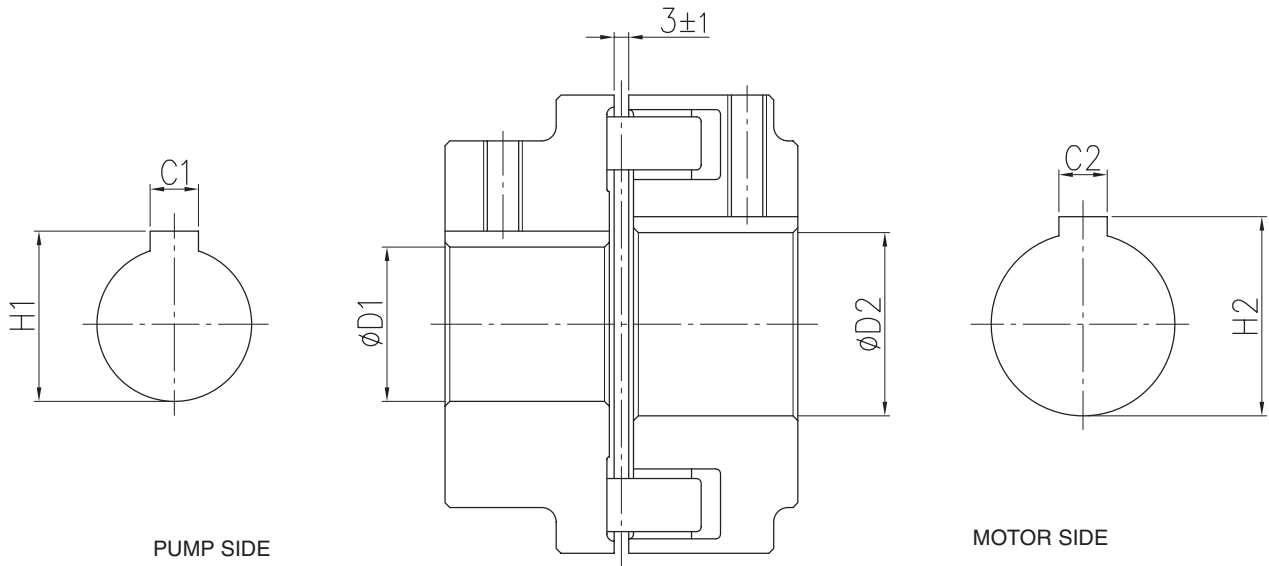

DIMENSIONAL TABLES up to 80 size

2 POLES

Pump type	kW	HP	Motor		Dimensions (mm)					
			Size	Type	D1	D2	C1	C2	H1	H2
65-250/30	30	40	200	B3	32	55	10	16	35,3	59,3
65-250/37	37	50	200	B3	32	55	10	16	35,3	59,3
80-160/11	11	15	160	B3	24	42	8	12	27,3	45,3
80-160/15R	15	20	160	B3	24	42	8	12	27,3	45,3
80-160/15	15	20	160	B3	24	42	8	12	27,3	45,3
80-160/18.5	18,5	25	160	B3	24	42	8	12	27,3	45,3
80-200/22	22	30	180	B3	32	48	10	14	35,3	51,8
80-200/30	30	40	200	B3	32	55	10	16	35,3	59,3
80-200/37	37	50	200	B3	32	55	10	16	35,3	59,3
80-200/37	37	50	200	B3	32	55	10	16	35,3	59,3
80-250/45	45	60	225	B3	32	55	10	16	35,3	59,3
80-250/55	55	75	250	B3	32	60	10	18	35,3	64,4

4 POLES

Pump type	kW	HP	Motor		Dimensions (mm)					
			Size	Type	D1	D2	C1	C2	H1	H2
65-250/4	4	5,5	112	B3	32	28	10	8	35,3	31,3
65-250/5.5	5,5	7,5	132	B3	32	38	10	10	35,3	41,3
80-160/1.5	1,5	2	90	B3	24	24	8	8	27,3	27,3
80-160/2.2R	2,2	3	100	B3	24	28	8	8	27,3	31,3
80-160/2.2	2,2	3	100	B3	24	28	8	8	27,3	31,3
80-200/3	3	4	100	B3	32	28	8	8	35,3	31,3
80-200/4R	4	5,5	12	B3	32	28	10	8	35,3	31,3
80-200/4	4	5,5	12	B3	32	28	10	8	35,3	31,3
80-250/5.5R	5,5	7,5	132	B3	32	38	10	10	35,3	31,3
80-250/5.5	5,5	7,5	132	B3	32	38	10	10	35,3	31,3
80-250/7.5	7,5	10	132	B3	32	38	10	10	35,3	31,3